

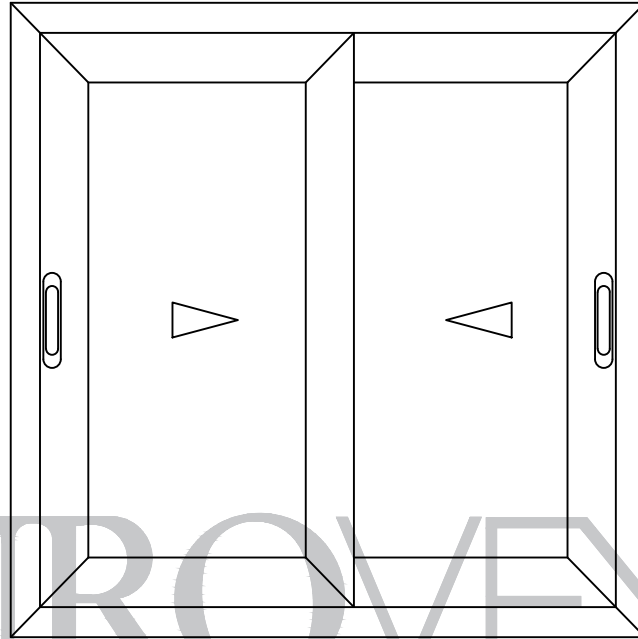

CORREDIZA SERIE 150



EUROVENT[®]

P R E M I U M

PREMIUM
SERIE
S150
CORREDIZO

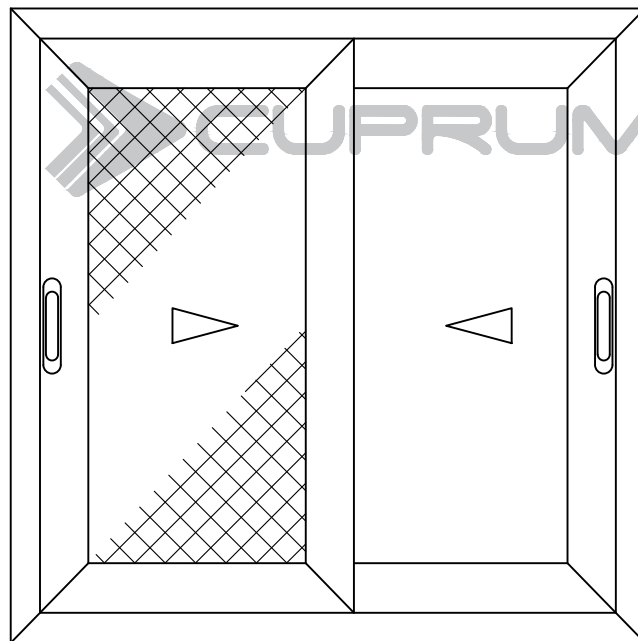

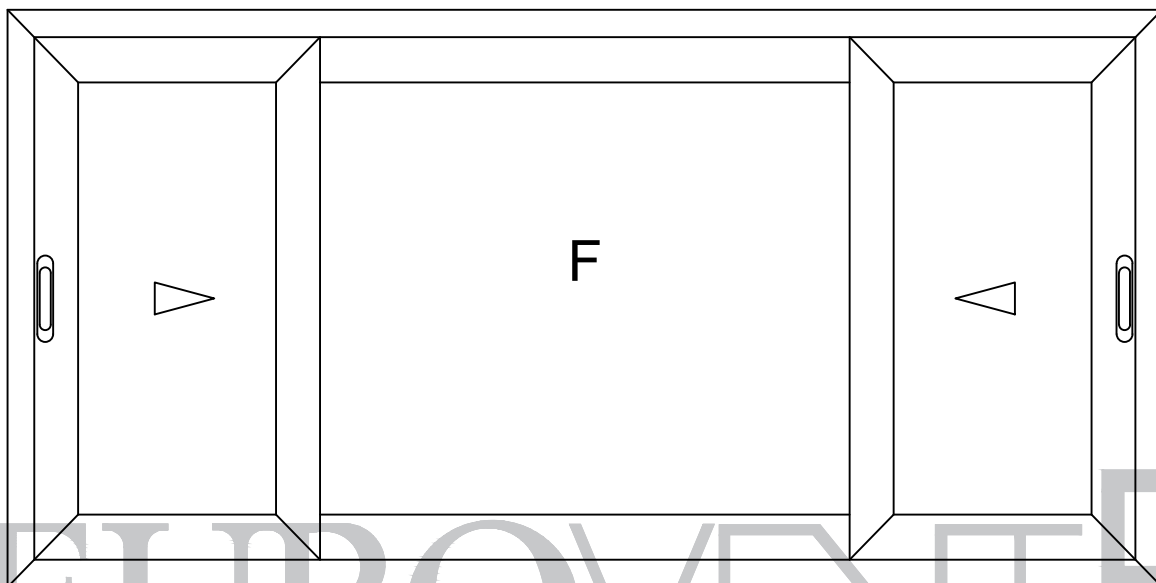

PREMIUM
SERIE

S 150



CORREDIZO

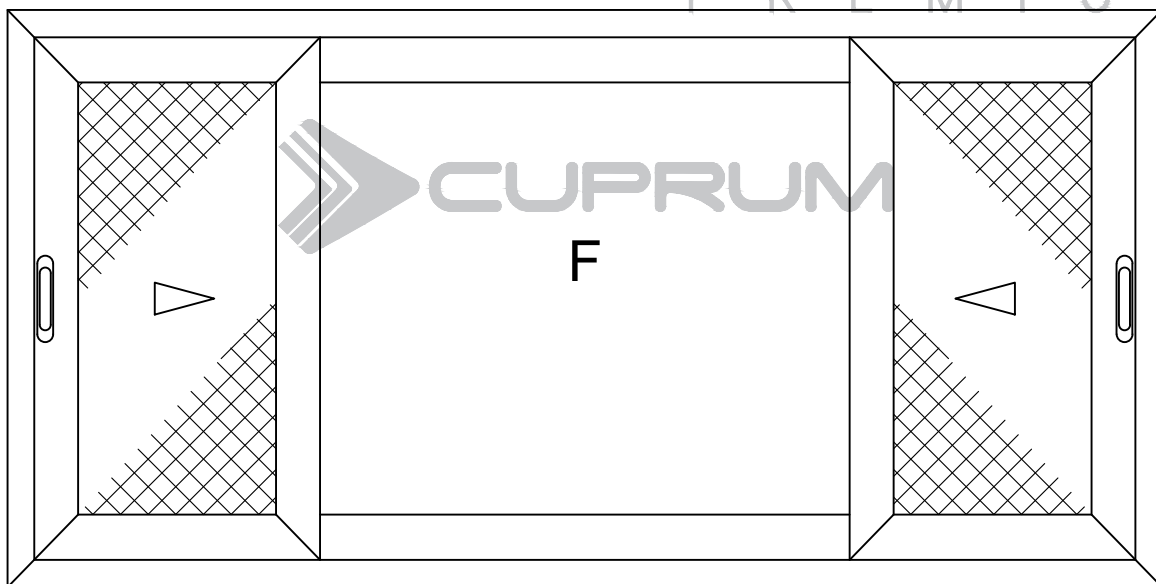

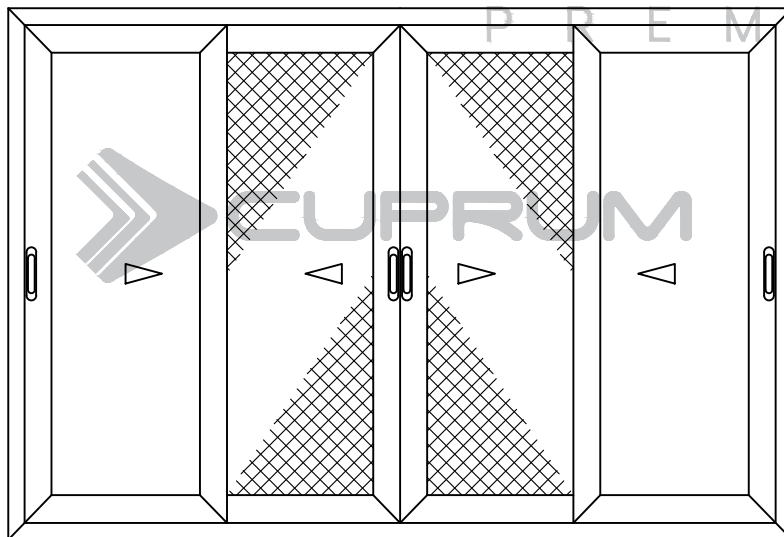
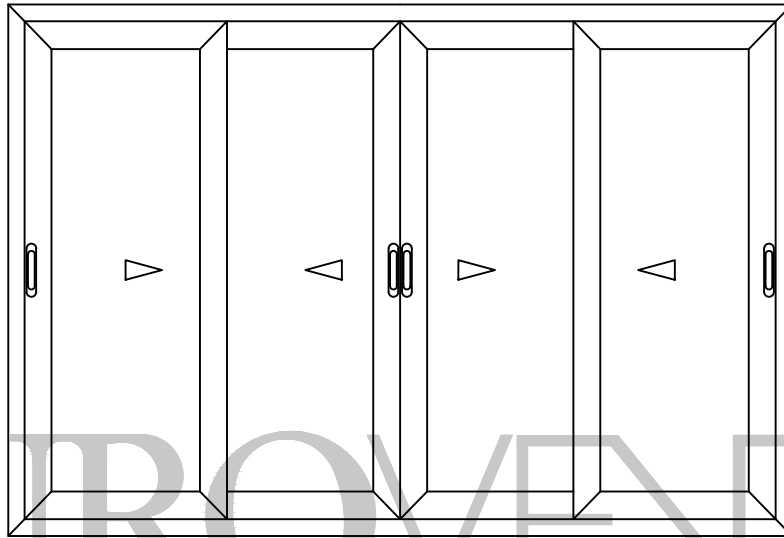

EUROVENT[®] PREMIUM SERIE S150

CORREDIZO

PREMIUM
SERIE
S150
CORREDIZO

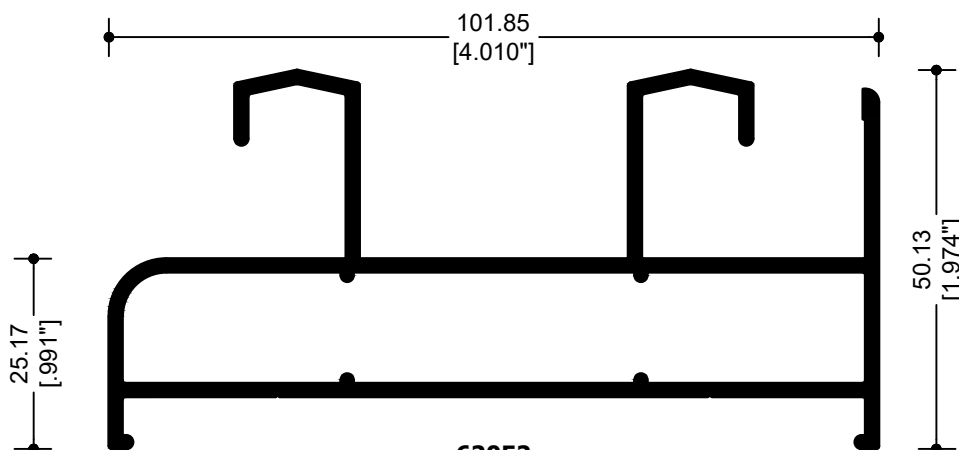

62052
RIEL DOBLE

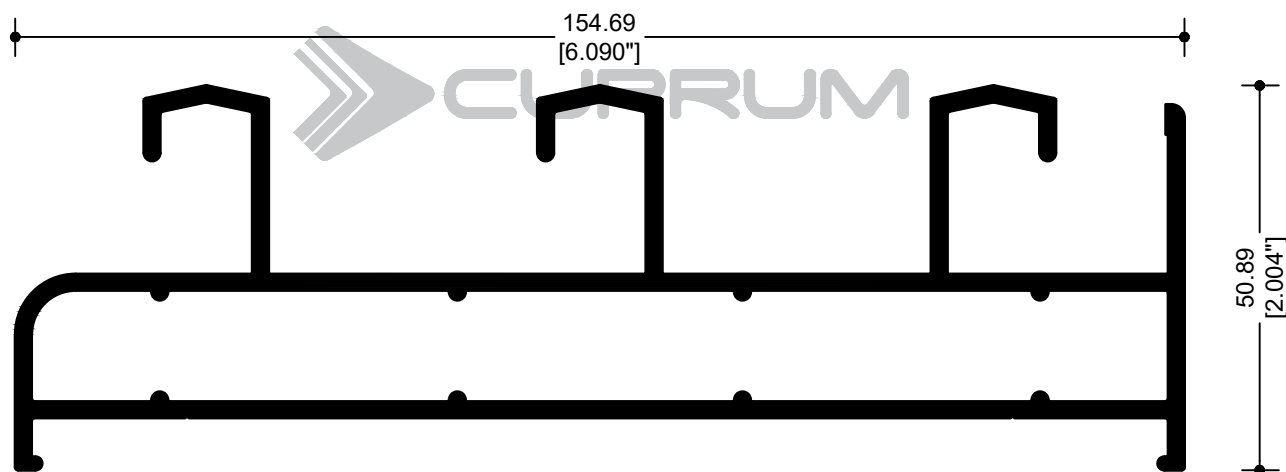
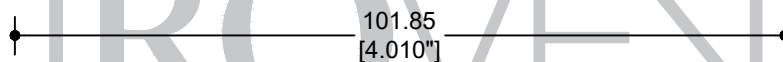

62054
RIEL TRIPLE

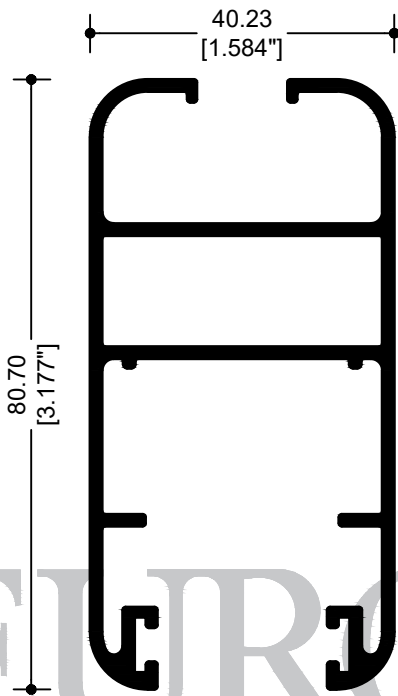

62055
CERCO 6mm

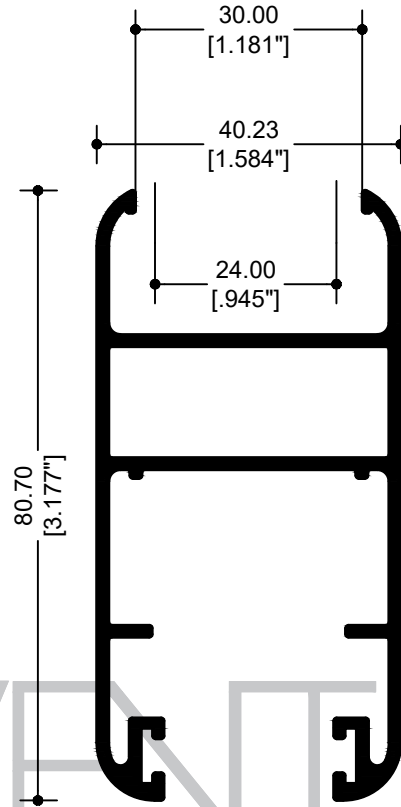

62056
CERCO DOBLE VIDRIO 24mm

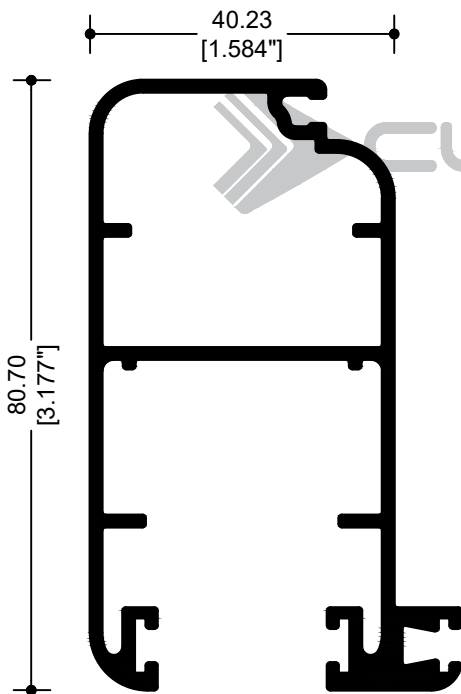

62057
MOSQUITERO

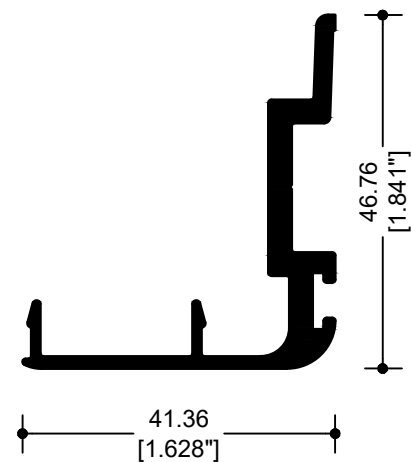

62058
TRASLAPE

EUROVENTA
PREMIUM

PREMIUM
SERIE
S150
CORREDIZO

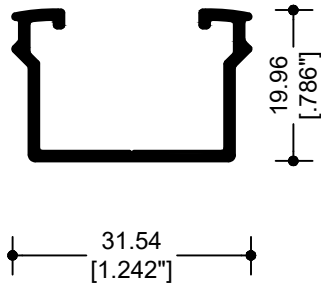

62060
ADAPTADOR CRISTAL 9mm.

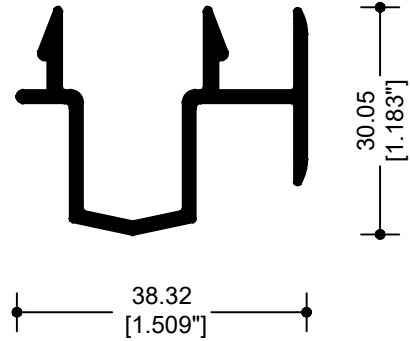

64206
ADAPTADOR OXO



PREMIUM

SERIE

S150



CORREDIZO

EUROVENT[®]

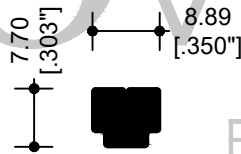

14412
CONECTOR

P R E M I U M

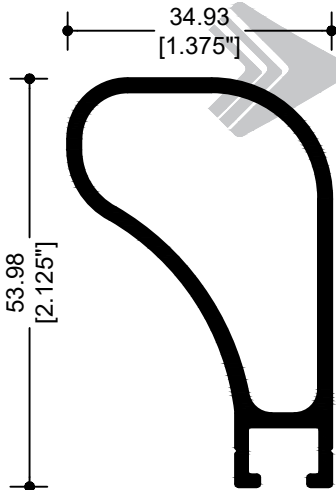

62014
REFUERZO

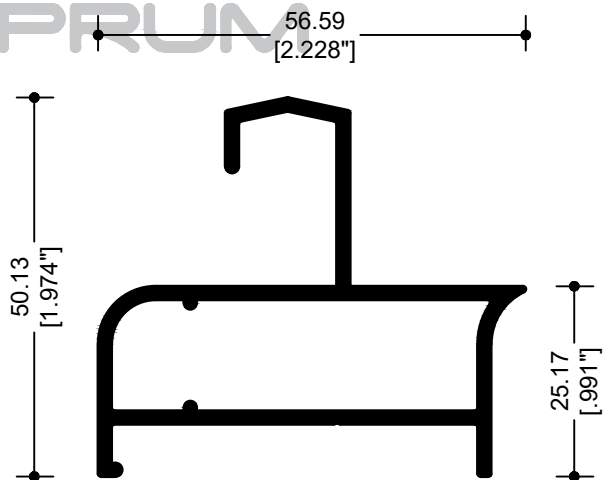

62091
ADAPTADOR RIEL

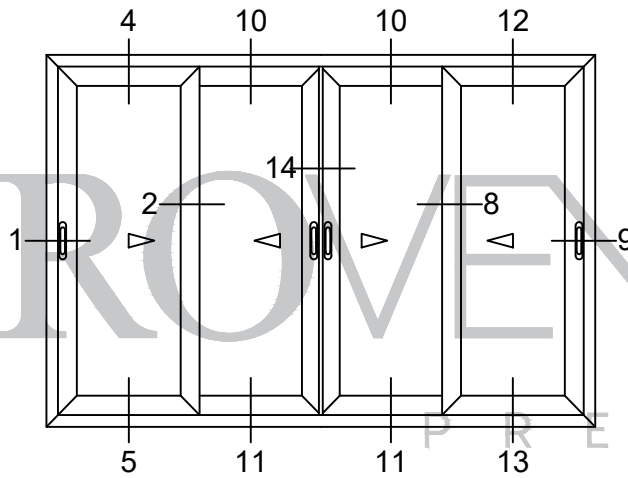
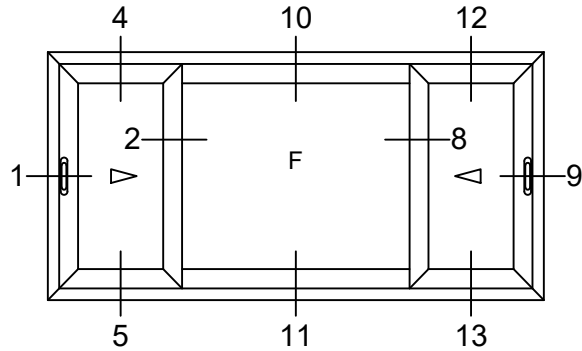
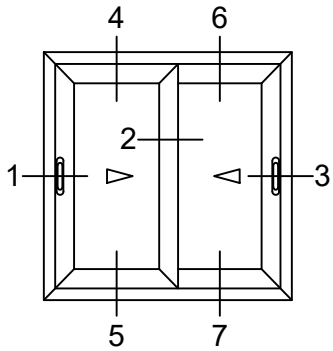

EUROVENT PREMIUM

PREMIUM SERIE S150 CORREDIZO

EXTERIOR CUPRUM

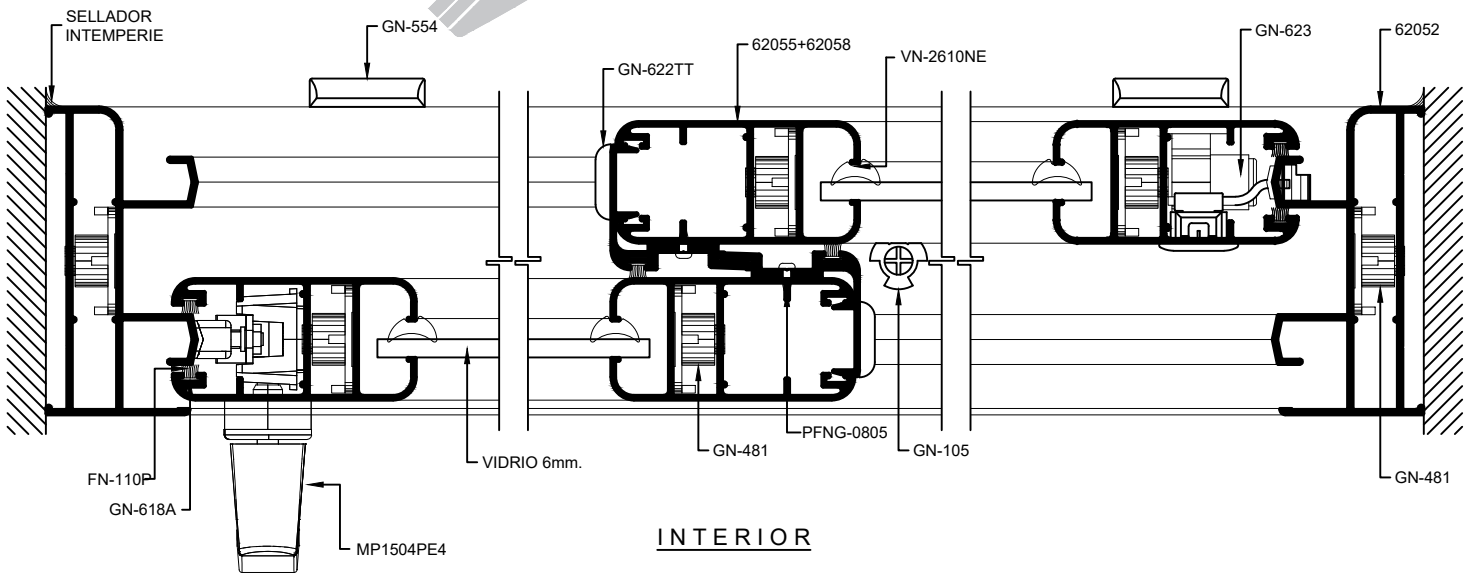

SECCIÓN 1

SECCIÓN 2

SECCIÓN 3

PREMIUM
SERIE
S150
CORREDIZO

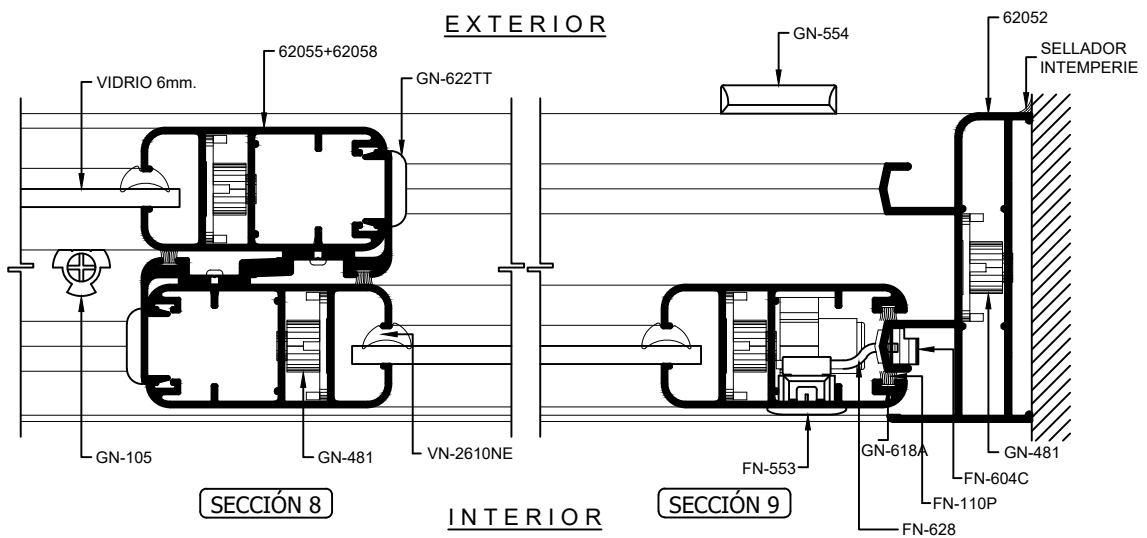
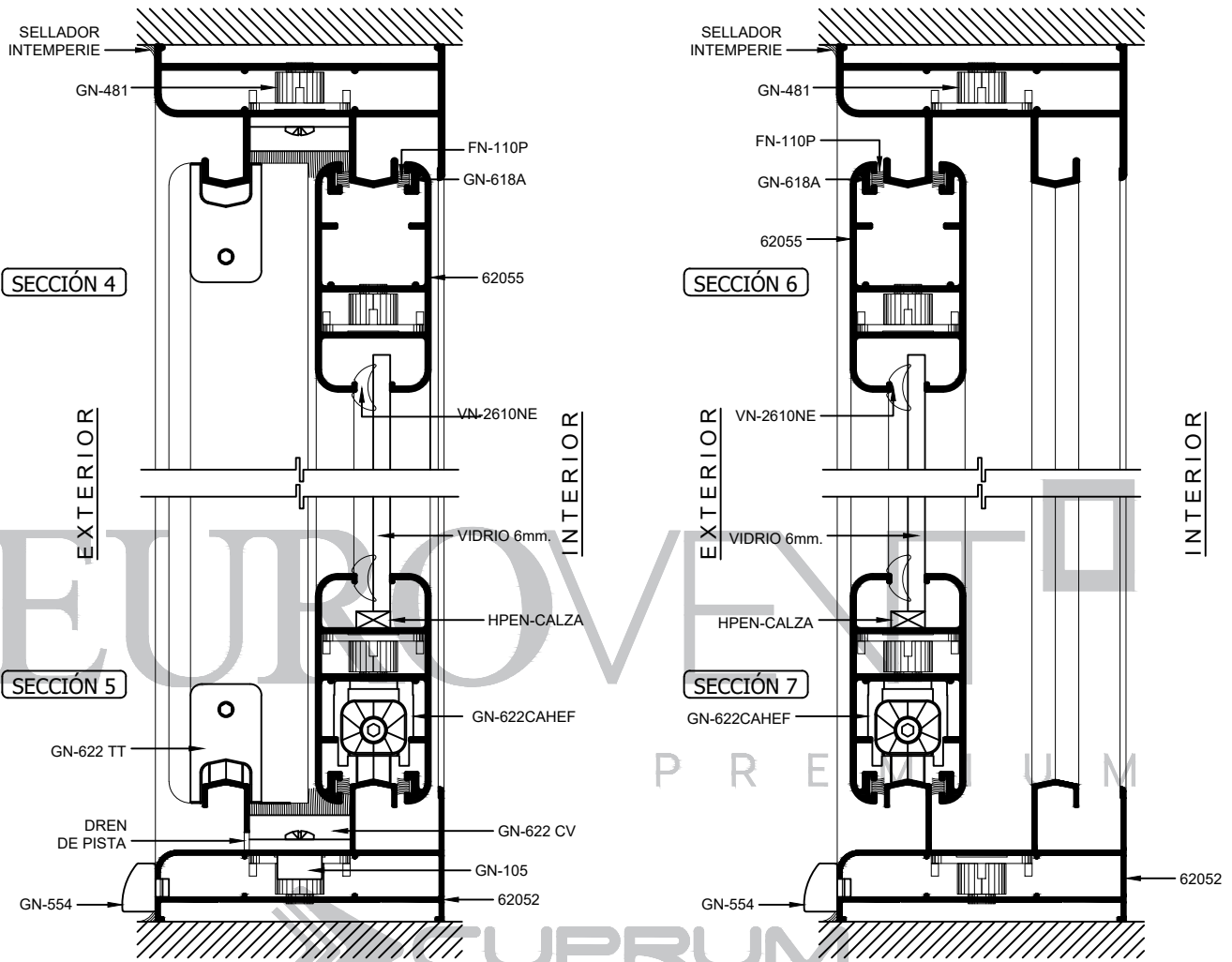

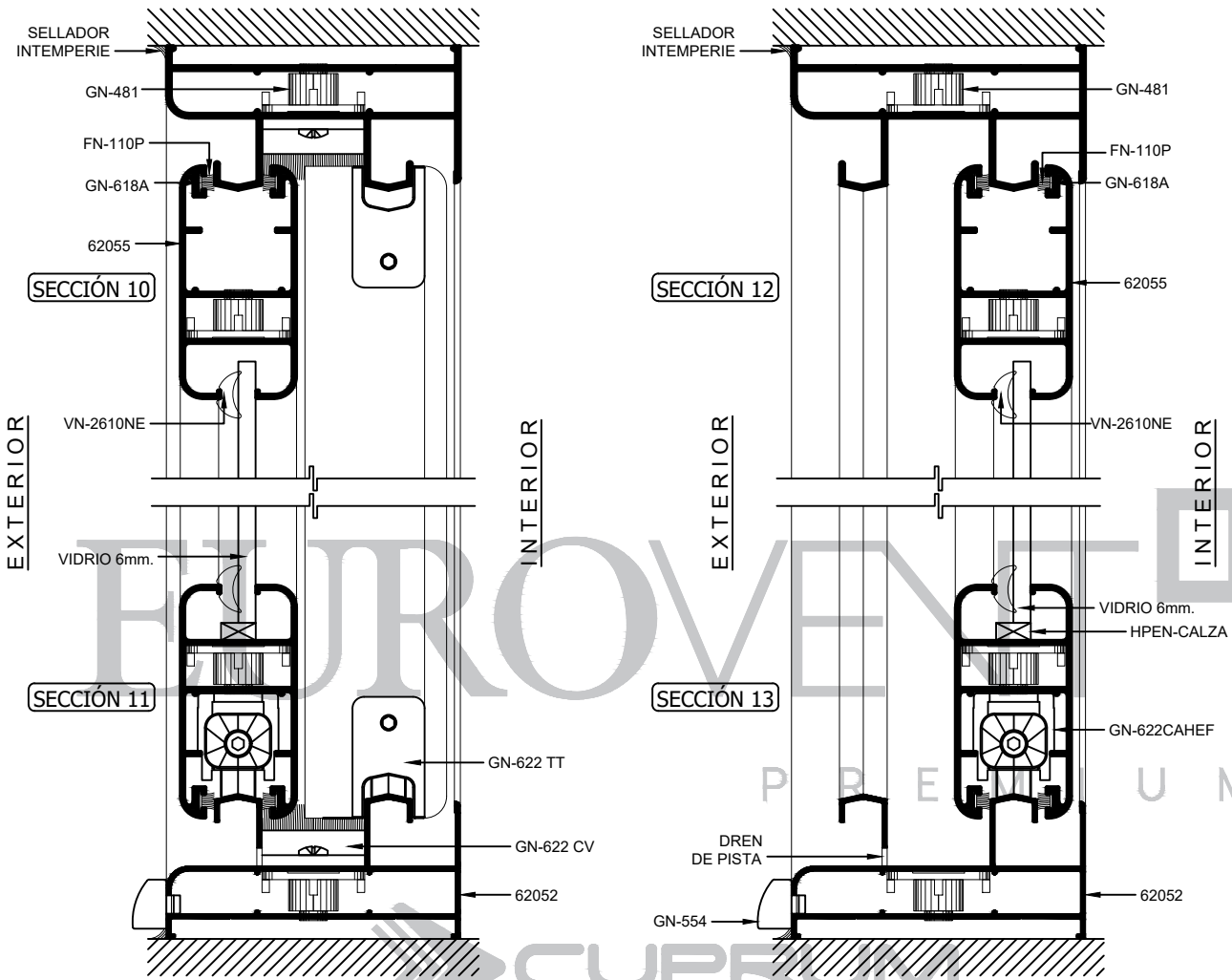

 PREMIUM
 SERIE
S150

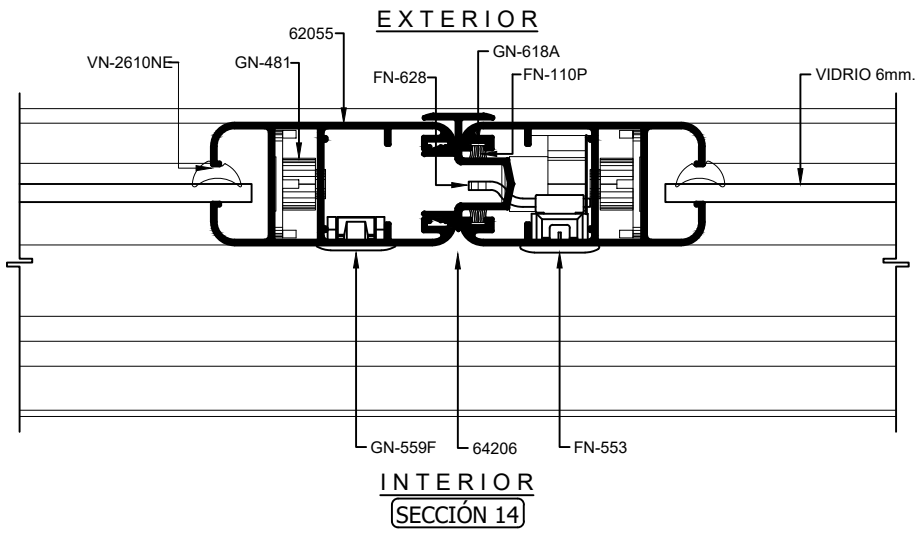

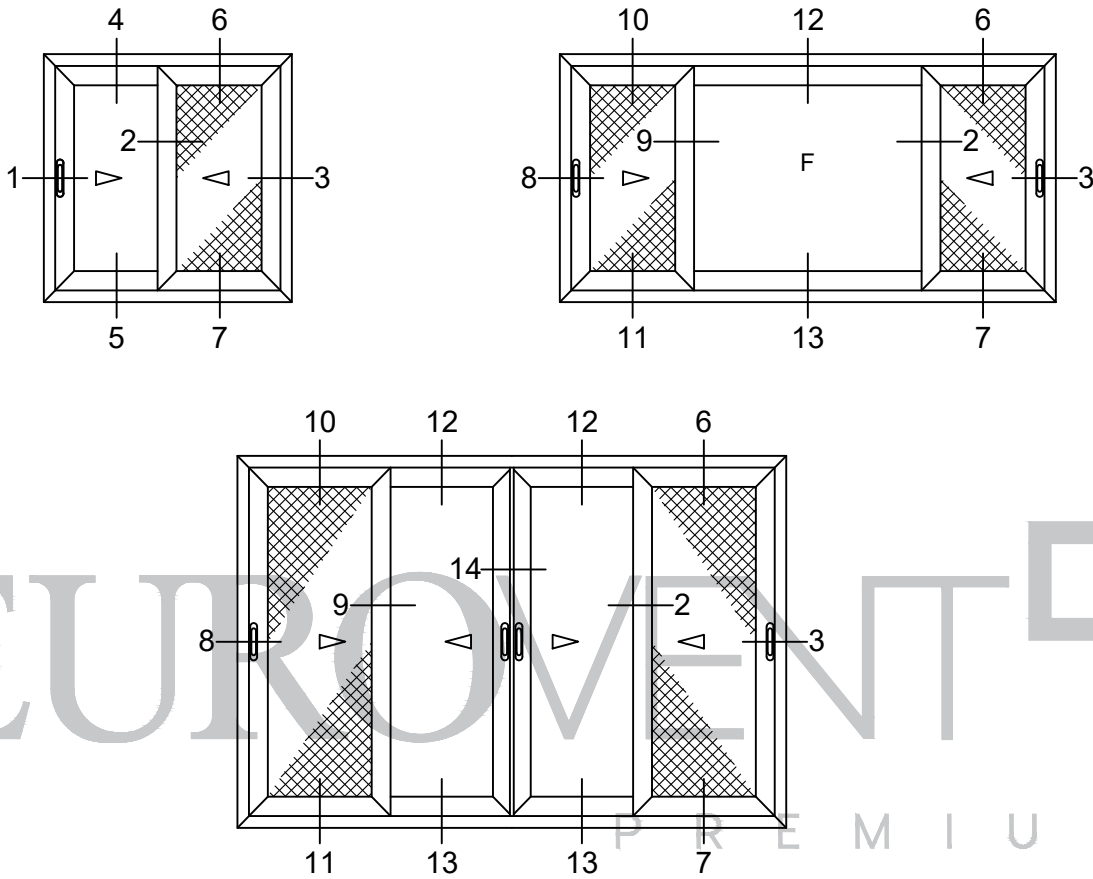

PREMIUM
SERIE
S150
CORREDIZO

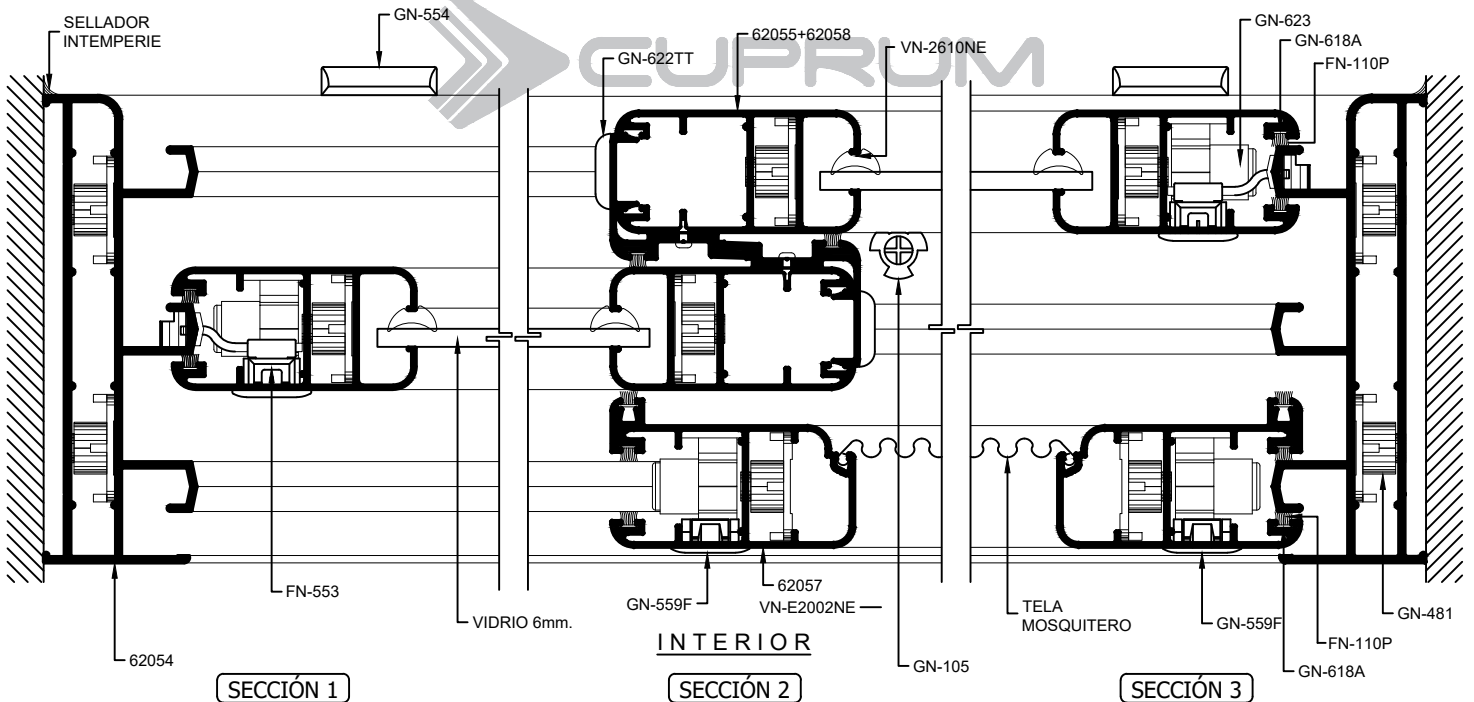

EXTERIOR

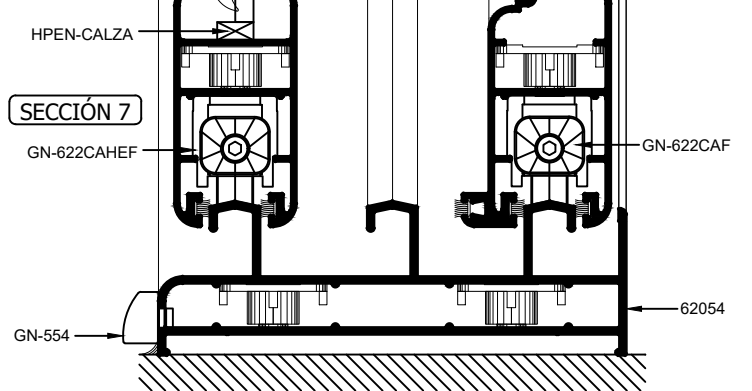
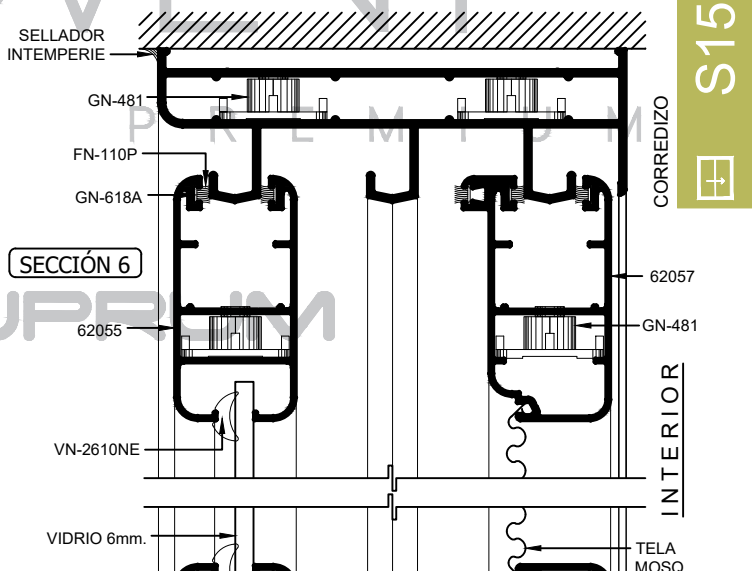
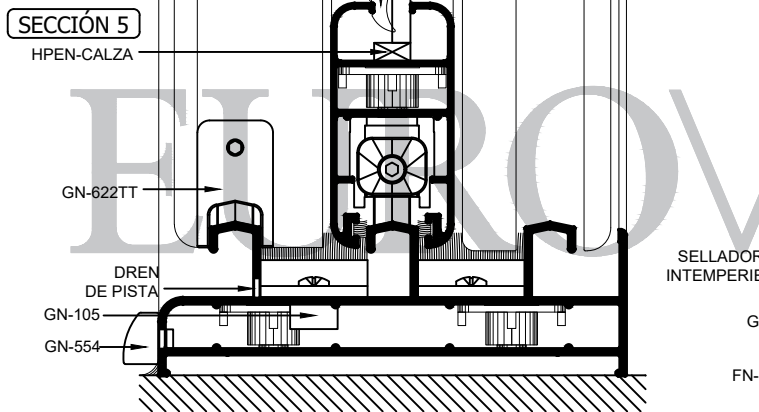
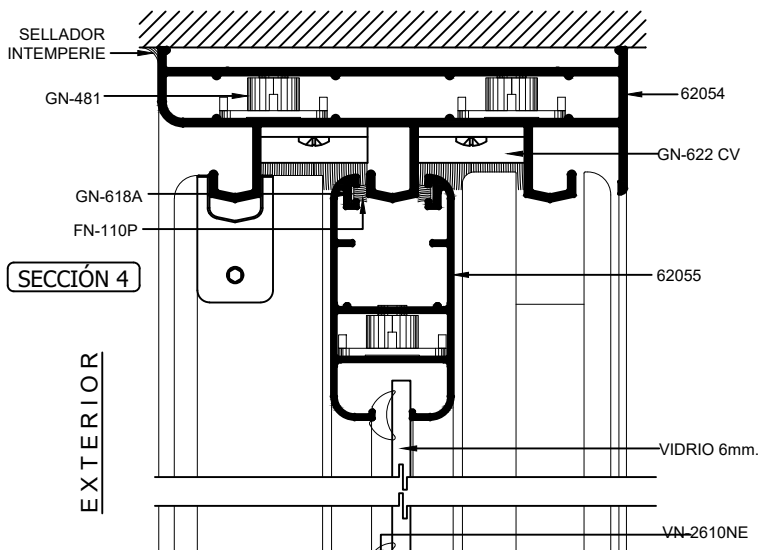



PREMIUM SERIE S150



PREMIUM
SERIE
S150
CORREDIZO

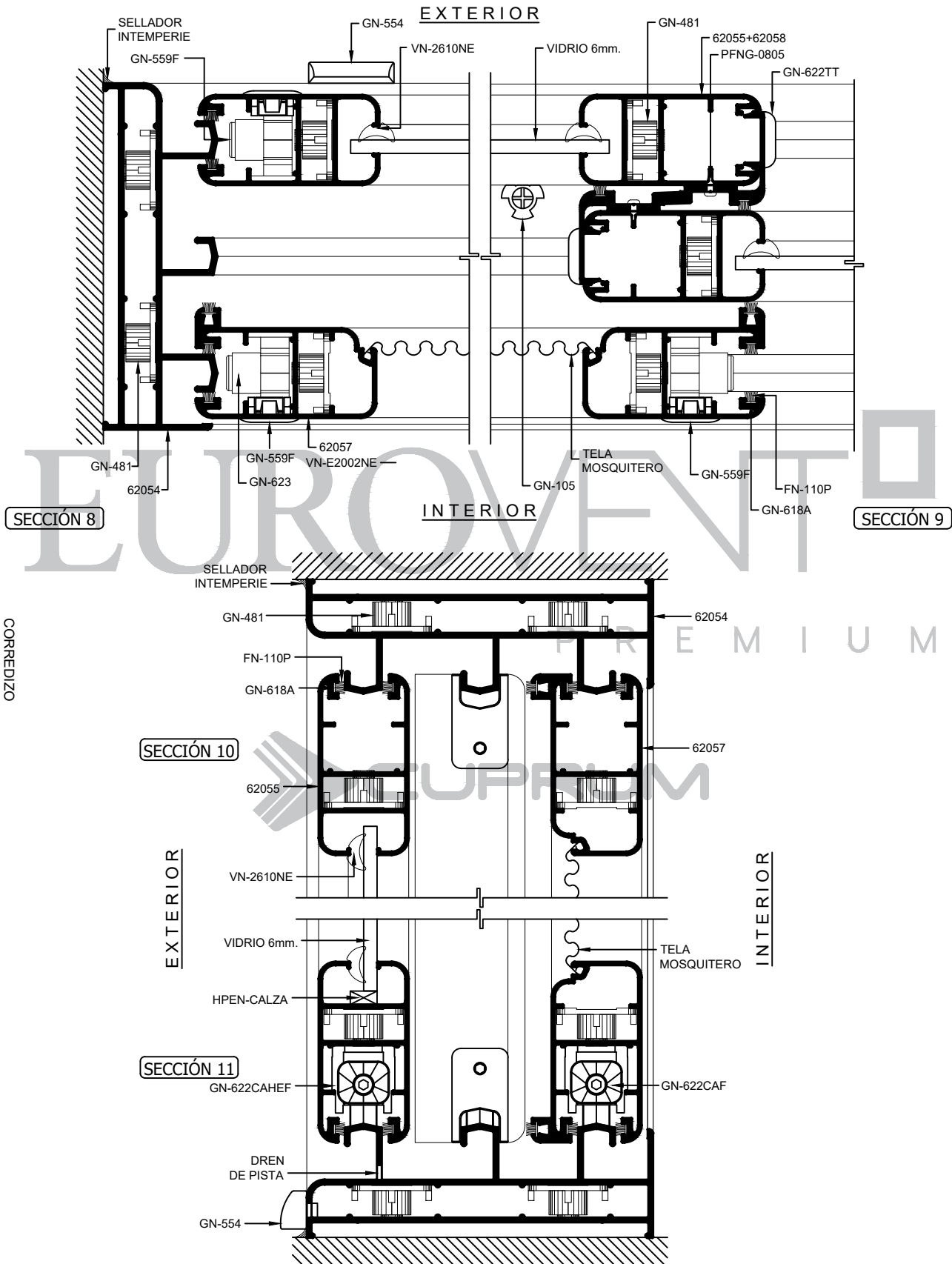

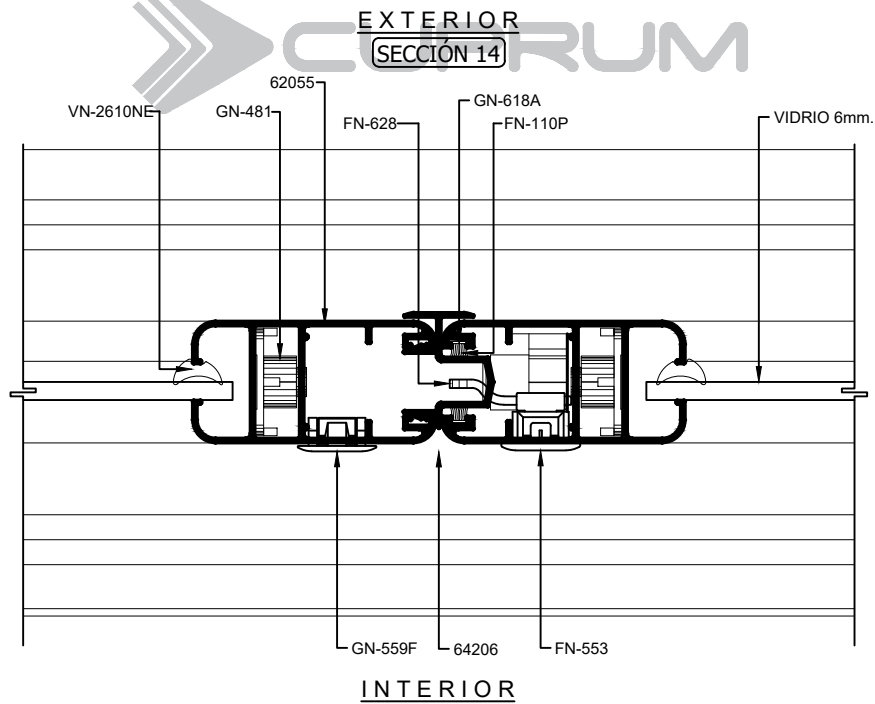
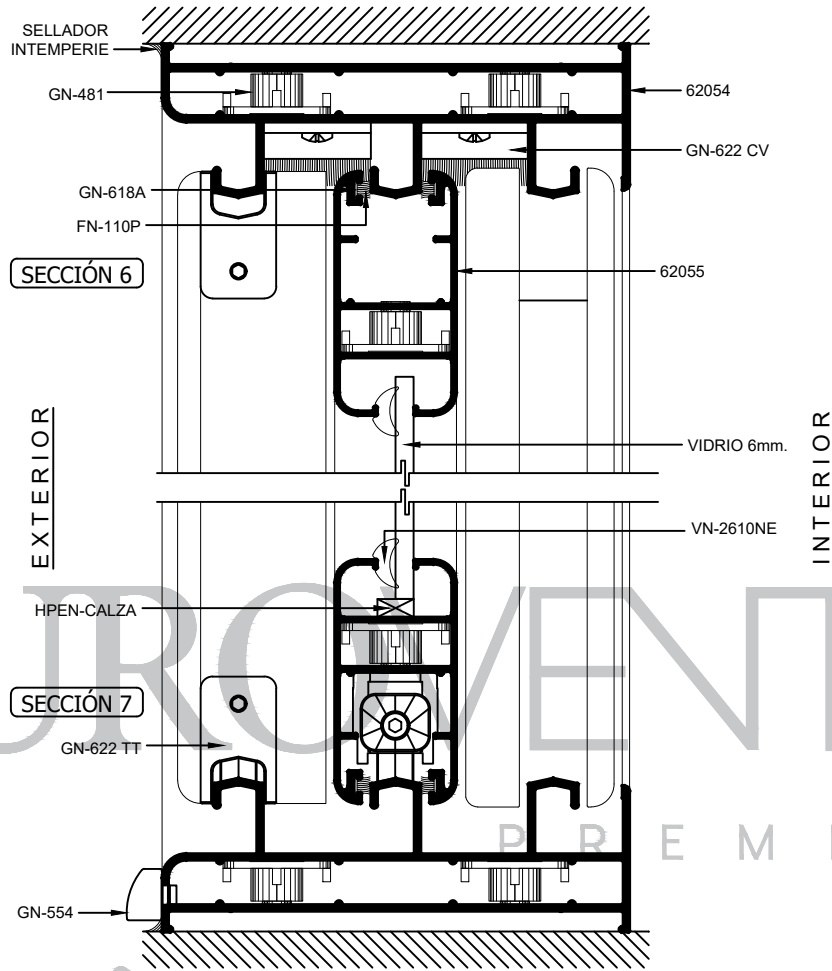

EUROVENT² PREMIUM

PREMIUM
SERIE
S150
CORREDIZO

CUPRUM

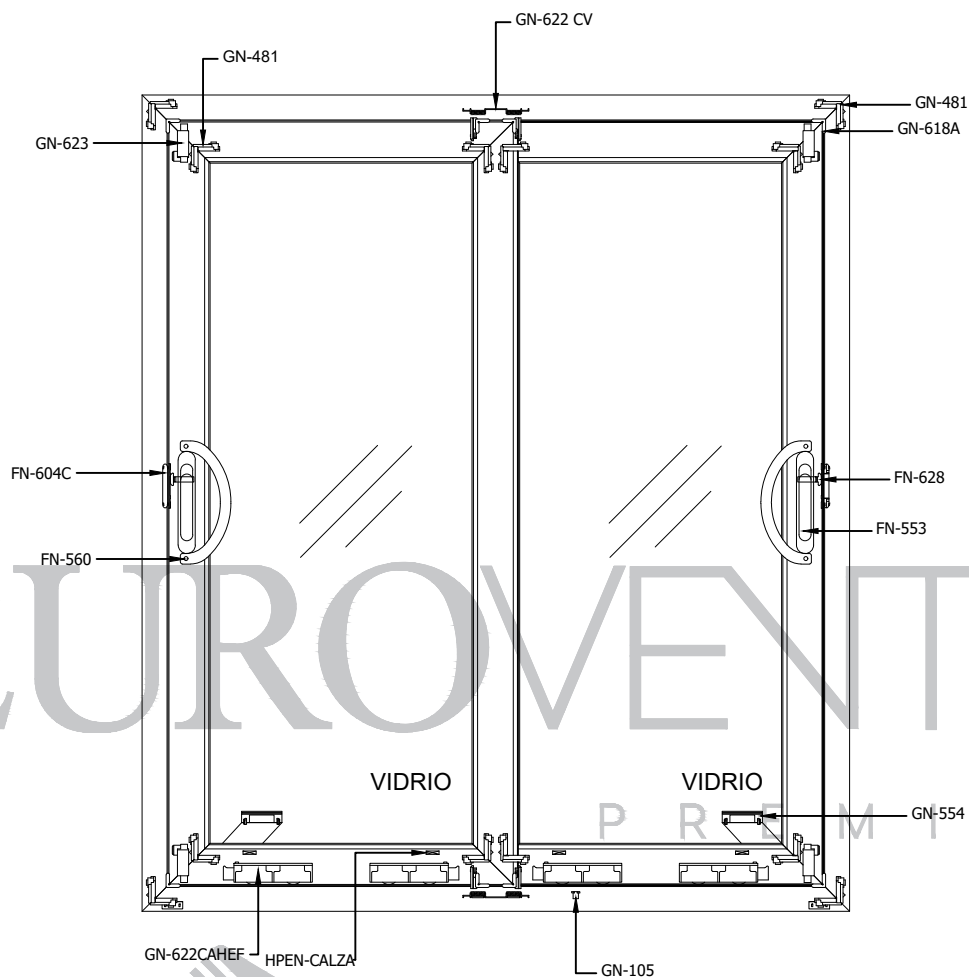

PREMIUM
SERIE
S150
CORREDIZO

CUPRUM

VENTANA CORREDIZA XX

CLAVE	DESCRIPCIÓN	PIEZAS
FN-110P	FELPA CON PLÁSTICO	4H+6L
GN-105	TAPÓN DESAGÜE	1
GN-481	ESCUADRA BOTÓN 421	12
FN-553	CIERRE GRANDE	1
MP1504PE4	MULTIPUNTO 4 PUNTOS	1
GN-554	TAPA DREN	2
FN-560	JALADERA SOBREPUESTA (OPCIONAL)	2
GN-623	CANDADO DE HOJA	4
GN-618A	ESCUADRA DE ALINEACIÓN	16
GN-622CAHEF	(100 KG POR CARRETILO - 200 KG. POR HOJA)	4
FN-604C	CONTRA	1
FN-628	GANCHO	1
GN-622 TT	TAPA TRASLAPE	4
GN-622 CV	CORTAVIENTOS	2
GN-102	TAPÓN CUBREPIJA	15

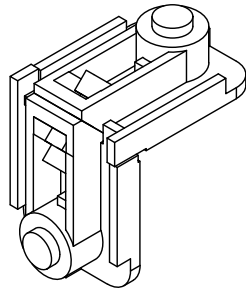

GN-481
O
GN-481C
ESCUADRA DE BOTÓN 421

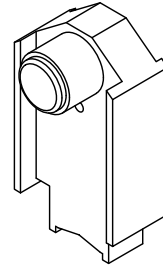

GN-623
CANDADO DE HOJA

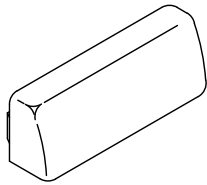

GN-554
TAPA DREN

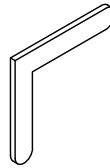

GN-618A
ESCUADRA DE ALINEACIÓN

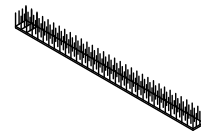

FN-110P
FELPA CON PLÁSTICO



VN-2610NE



GN-105
TAPÓN DESAGÜE

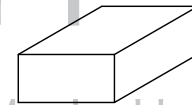

HPEN-CALZA
1/4 " x 3/8"

PREMIUM
SERIE
S150
CORREDIZO

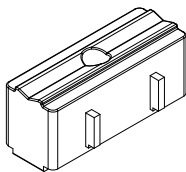

GN-623
CALZO DE HOJA FIJA

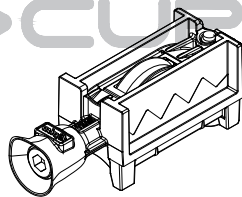

GN-622CAF
(50KG POR CARRETILLA
PARA MOSQUITERO

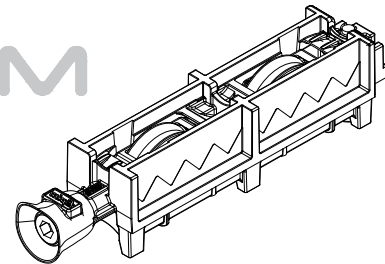

GN-622CAHEF
100kg POR CARRETILLA -
200 KG. POR HOJA



GN-102D
TAPÓN CUBREPIJA

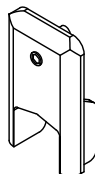

GN-622TT
TAPA TRASLAPE

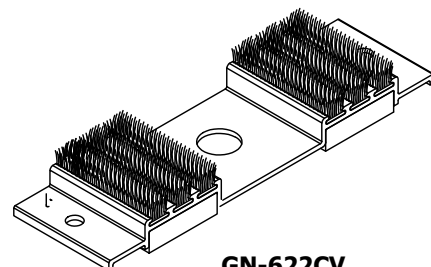

GN-622CV
CORTAVIENTOS (2)

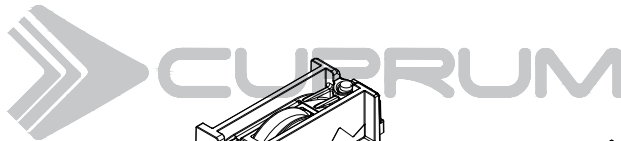



FN-553 PUERTA
CIERRE GRANDE

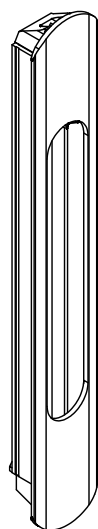

GN-559F
UÑERO EMBUTIDO

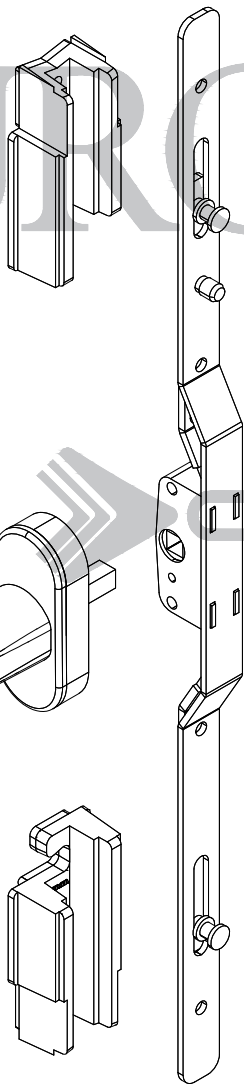

MP1504PE4
MULTIPUNTO 4 PUNTOS

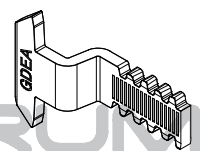

FN - 628
GANCHO

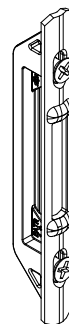

FN-604C
ENGANCHE
(CONTRA
MARCO)

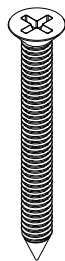

PFNG-1020
#10x2



PFNG-0805
#8x1/2"



VN-E2002NE
VINIL PARA MOSQUITERO

PREMIUM
SERIE
S150
CORREDIZO

EUROVENT[®]
PREMIUM

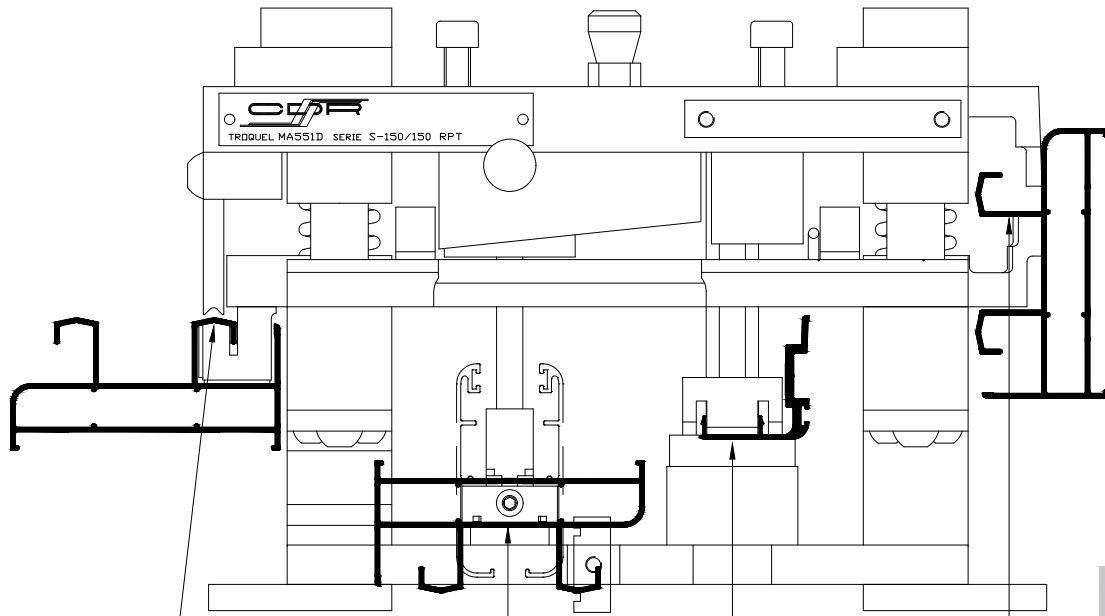

OPERACIÓN F

OPERACIÓN C

OPERACIÓN E

OPERACIÓN A

EUROVENT[®]

P R E M I U M

PREMIUM
SERIE
S150
CORREDIZO

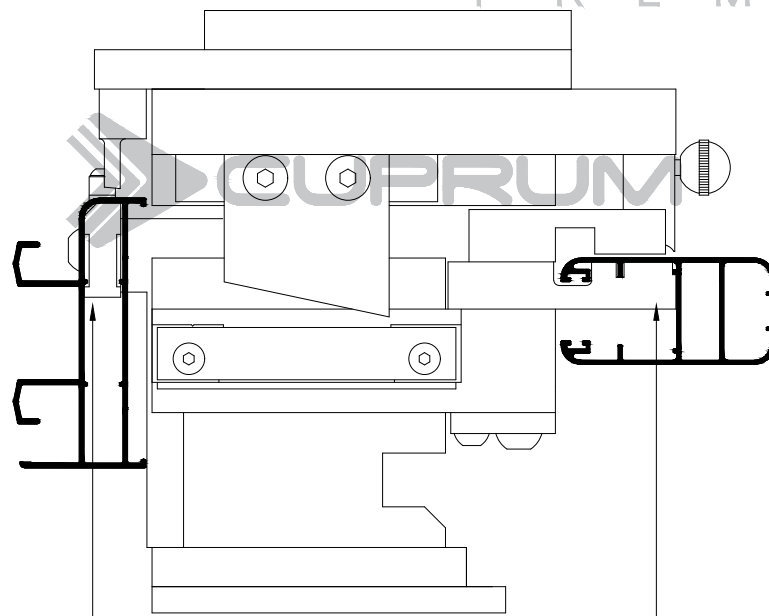

OPERACIÓN D

OPERACIÓN B

PARA REALIZAR TODAS LAS OPERACIONES DE TROQUELADO, EL MATERIAL DEBE DE ESTAR CORTADO A MEDIDA DE FABRICACIÓN

OPERACIÓN A

62052 RIEL DOBLE
62054 RIEL TRIPLE



PREMIUM

SERIE

S150



CORREDIZO

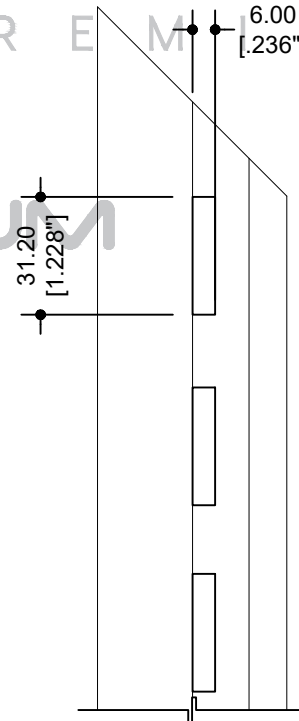
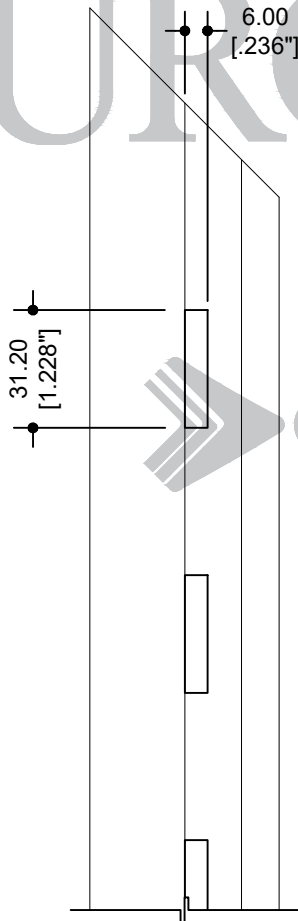

SE RECOMIENDA HACER 3 DRENES DE PISTA EQUIDISTANTES POR METRO LINEAL
NO HACER DRENES DE PISTA DEBAJO DE LA HOJA CORREDIZA
NO HACER DRENES DE PISTA EN LA PISTA INTERIOR
EN EL RIEL TRIPLE SE HACEN DRENES SEGÚN LA SOLUCIÓN DEL CANCEL

OPERACIÓN B

62055 CERCO 6mm
 62056 CERCO 24mm
 62057 MOSQUITERO

CIERRE BRIO

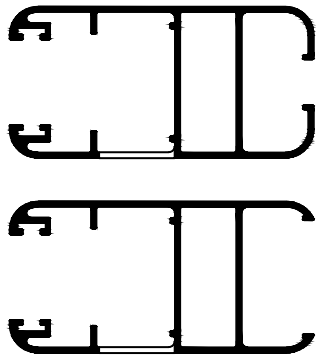

UÑERO

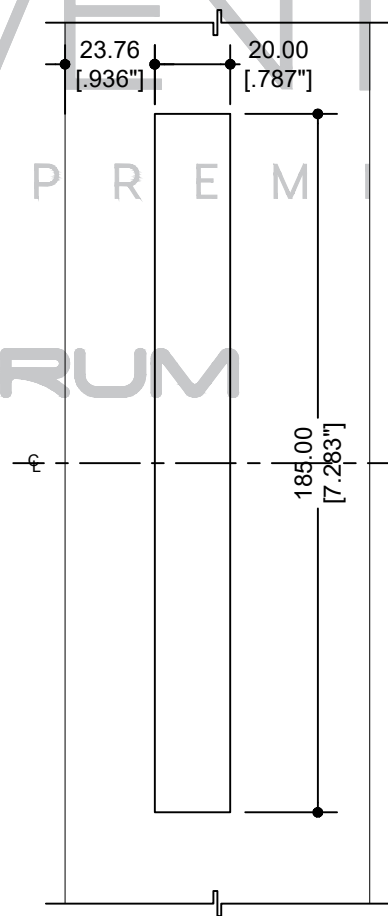
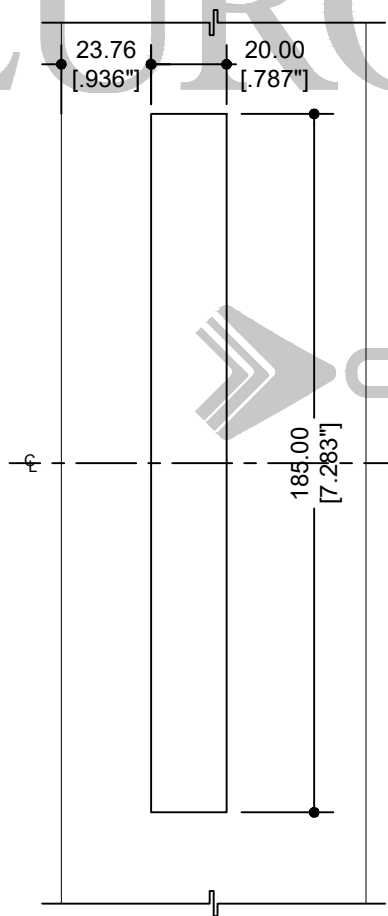
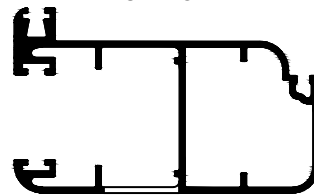

EUROVENT[®] PREMIUM

CUPRUM

PREMIUM
 SERIE
S150
 CORREDIZO

OPERACIÓN C

62052 RIEL DOBLE

ESCUADRA DE BOTÓN HOR.

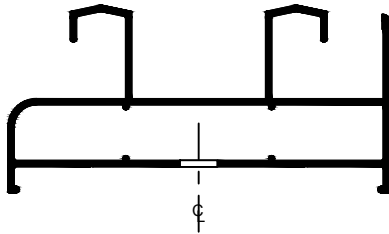

ESCUADRA DE BOTÓN VER.

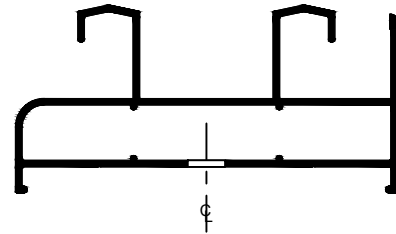

PREMIUM

SERIE

S150



CORREDIZO

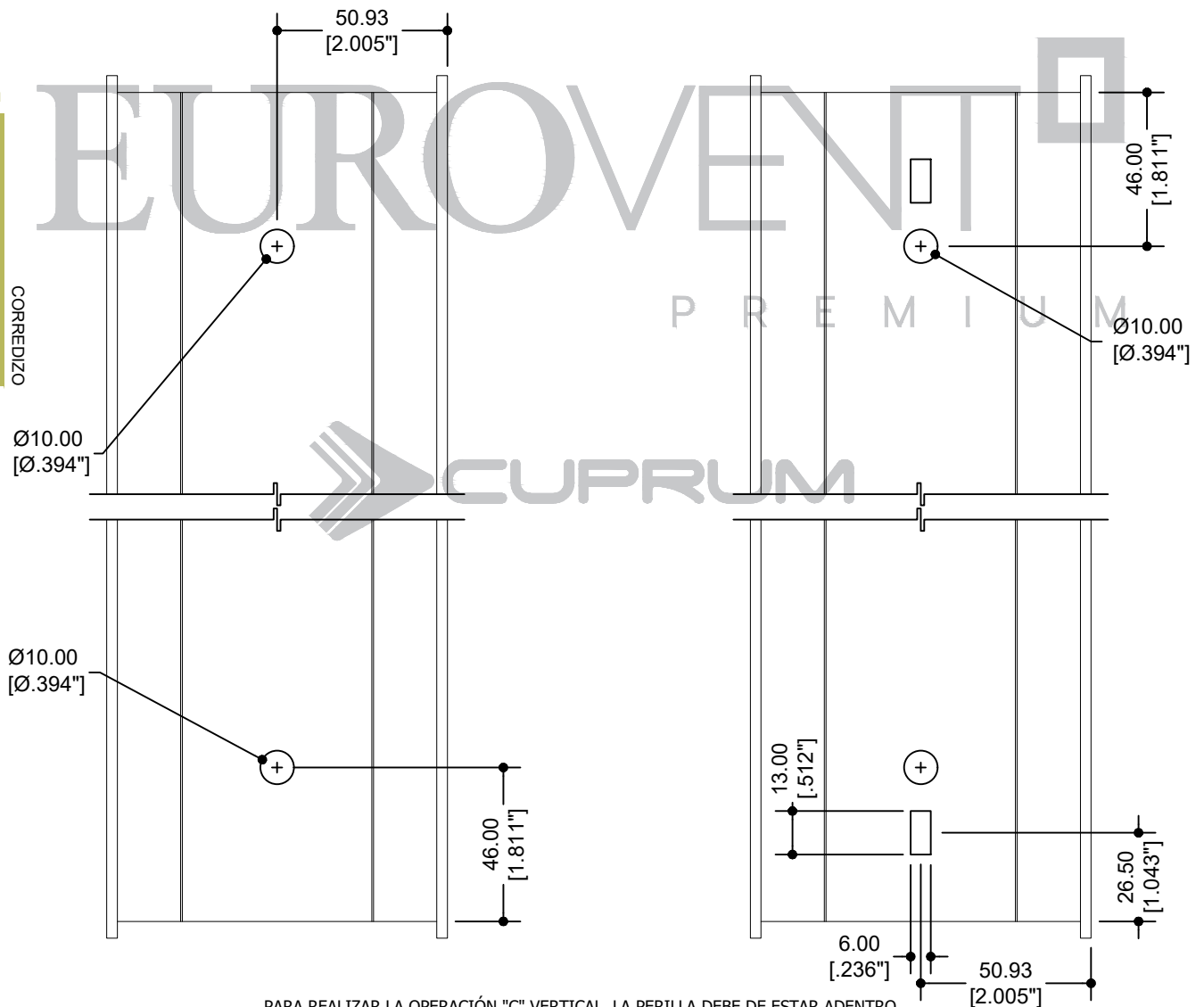

PARA REALIZAR LA OPERACIÓN "C" VERTICAL, LA PERILLA DEBE DE ESTAR ADENTRO
 PARA REALIZAR LA OPERACIÓN "C" HORIZONTAL, LA PERILLA DEBE DE ESTAR AFUERA

OPERACIÓN C

62054 RIEL TRIPLE

ESCUADRA DE BOTÓN HOR.

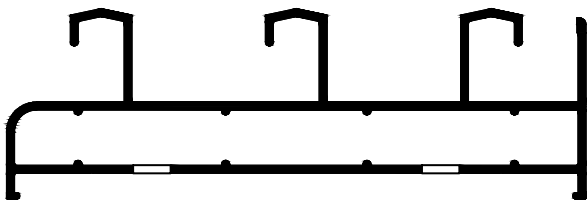

ESCUADRA DE BOTÓN VER.

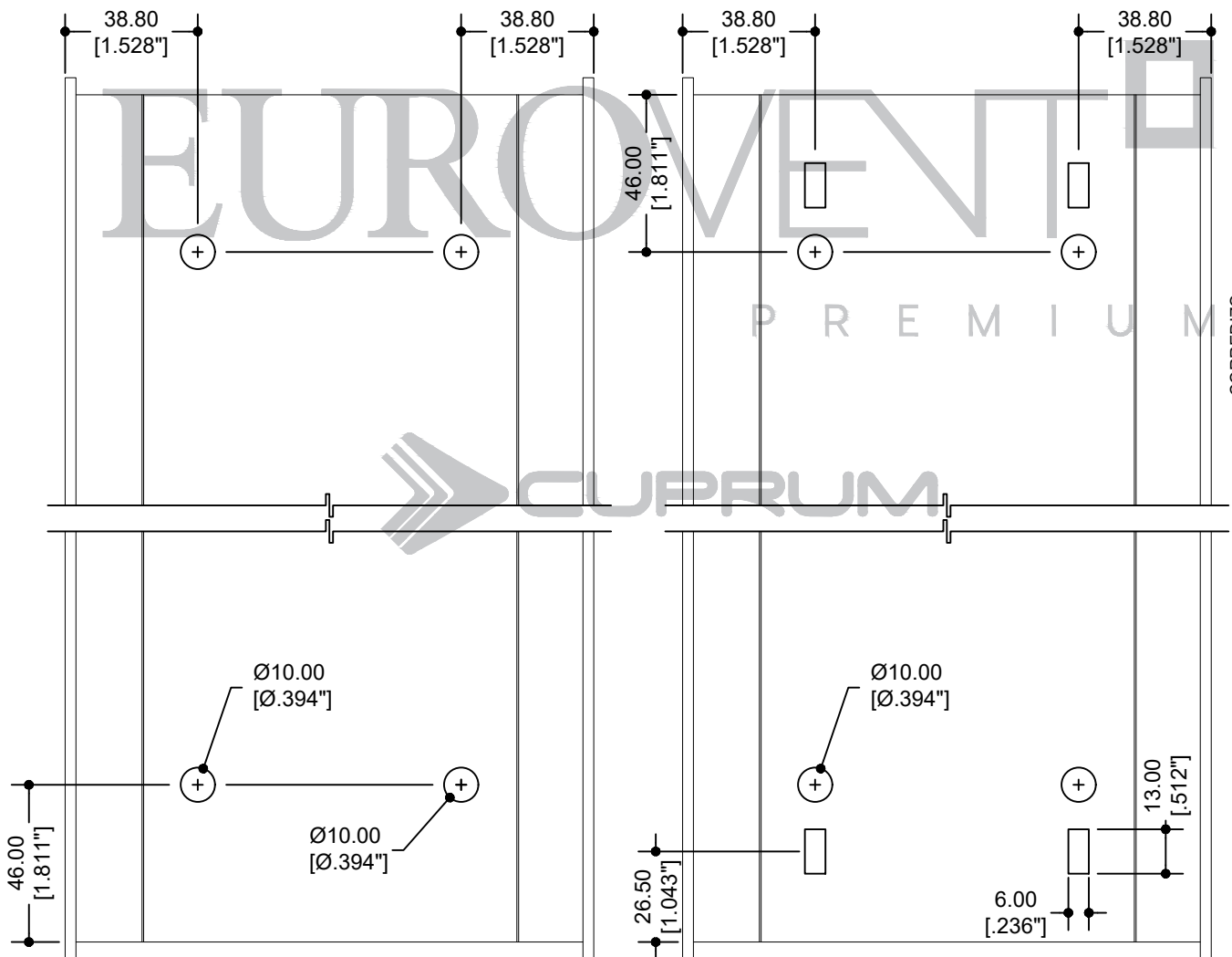
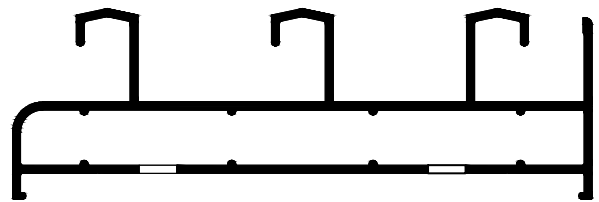

 PREMIUM
 SERIE
S150

 CORREDIZA

PARA REALIZAR LA OPERACIÓN "C" VERTICAL, LA PERILLA DEBE DE ESTAR ADENTRO
 PARA REALIZAR LA OPERACIÓN "C" HORIZONTAL, LA PERILLA DEBE DE ESTAR AFUERA

PARA REALIZAR LA OPERACIÓN "C" VERTICAL, LA PERILLA DEBE DE ESTAR ADENTRO
 PARA REALIZAR LA OPERACIÓN "C" HORIZONTAL, LA PERILLA DEBE DE ESTAR AFUERA

OPERACIÓN C

- 62055 CERCO 6mm
- 62056 CERCO 24mm
- 62057 MOSQUITERO

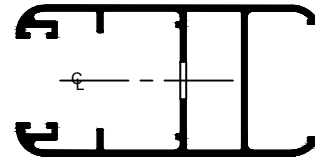
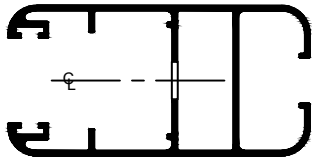

ESCUADRA DE BOTÓN HOR.

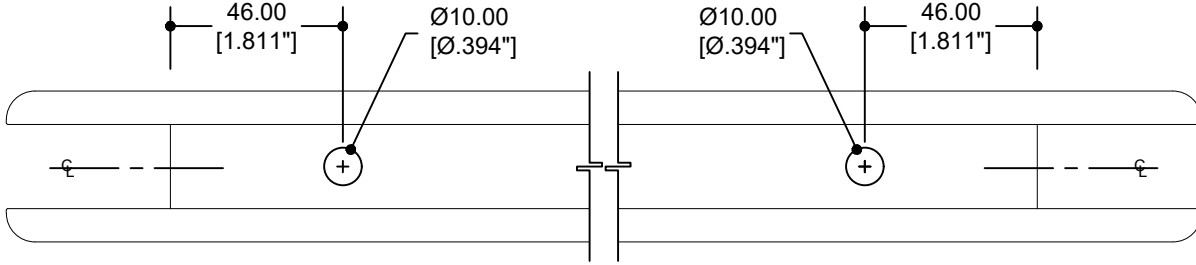

ESCUADRA DE BOTÓN VER.

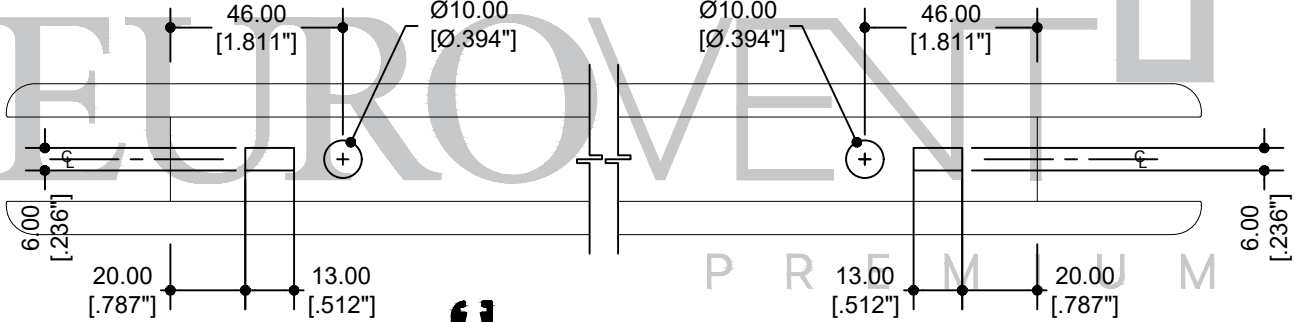

ESCUADRA DE BOTÓN HOR.

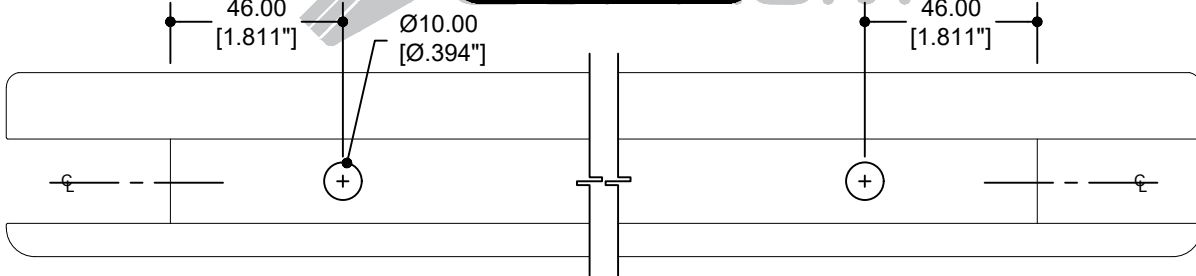

ESCUADRA DE BOTÓN VER.

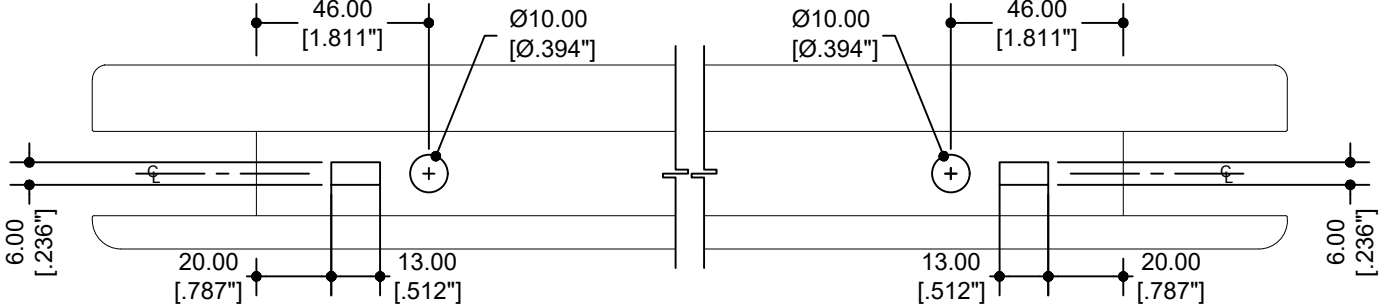

PREMIUM
 SERIE
S150
 CORREDIZO

OPERACIÓN D

DRENE TUBULAR
62052 RIEL DOBLE

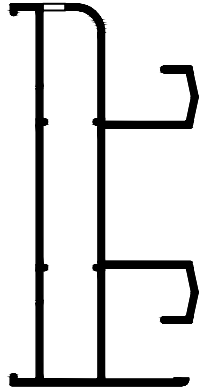

OPERACIÓN MANUAL

DRENE TUBULAR
62054 RIEL TRIPLE

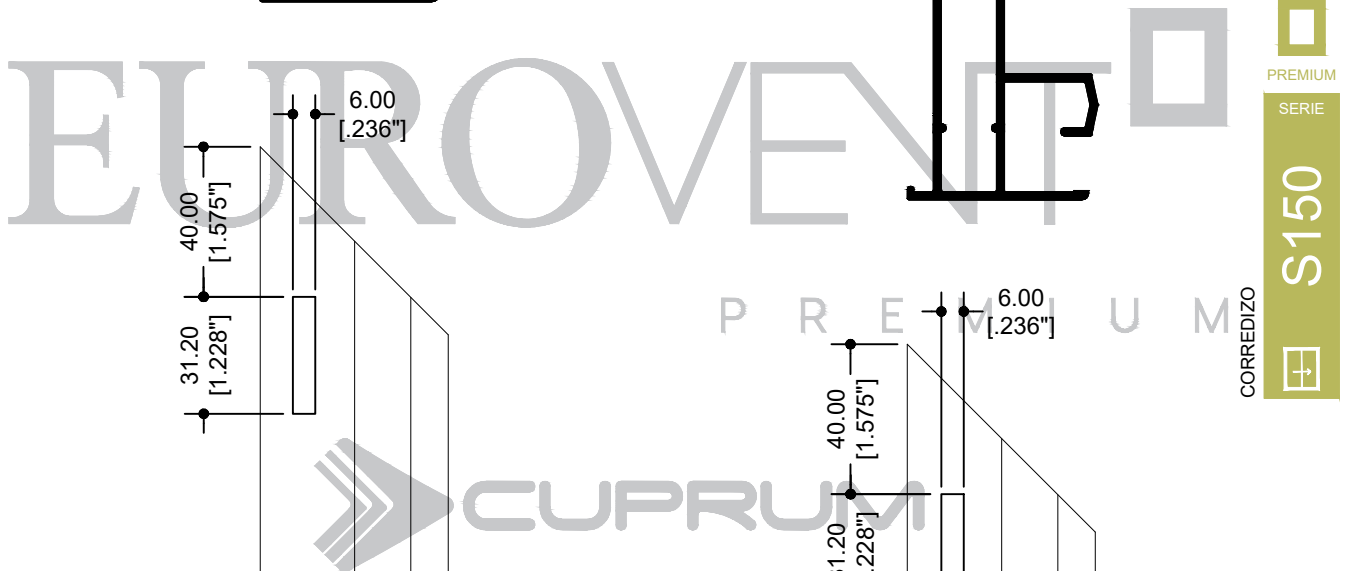
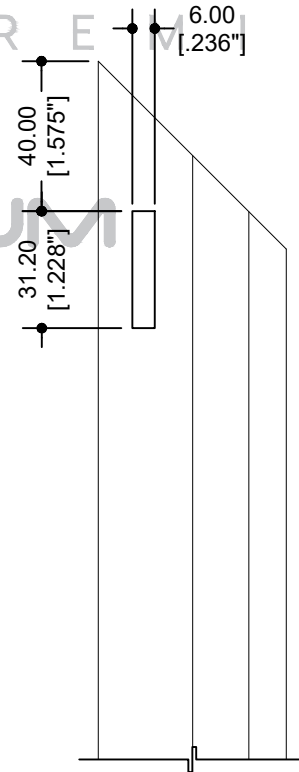
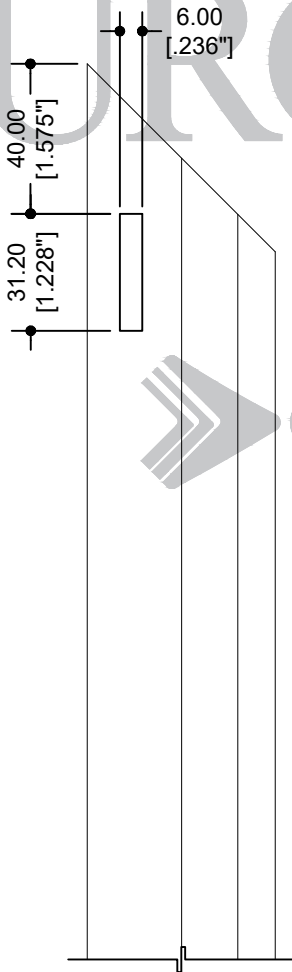
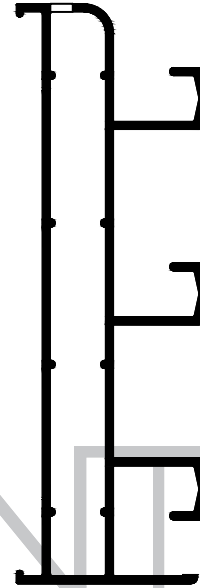



 PREMIUM
 SERIE
S150

 CORREDIZO

OPERACIÓN E

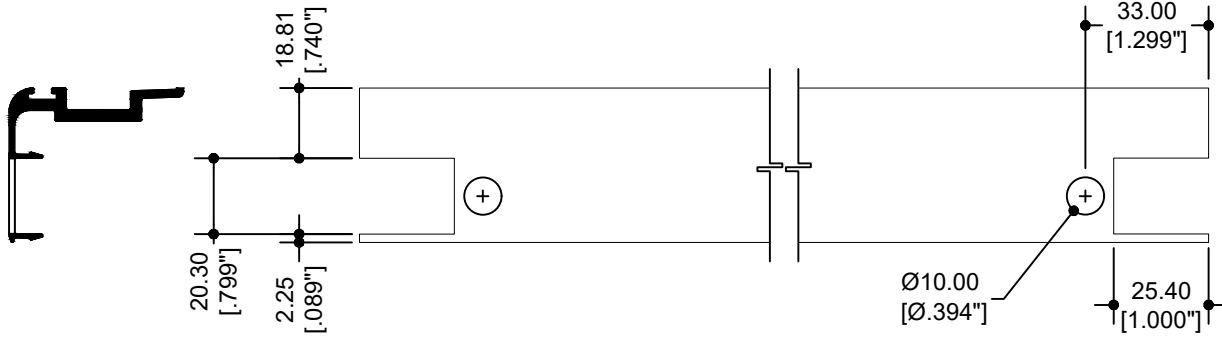
62058 TRASLAPE



OPERACIÓN F

CONTRA DE CIERRE
62058 TRASLAPE



PREMIUM
SERIE
S150
CORREDIZO

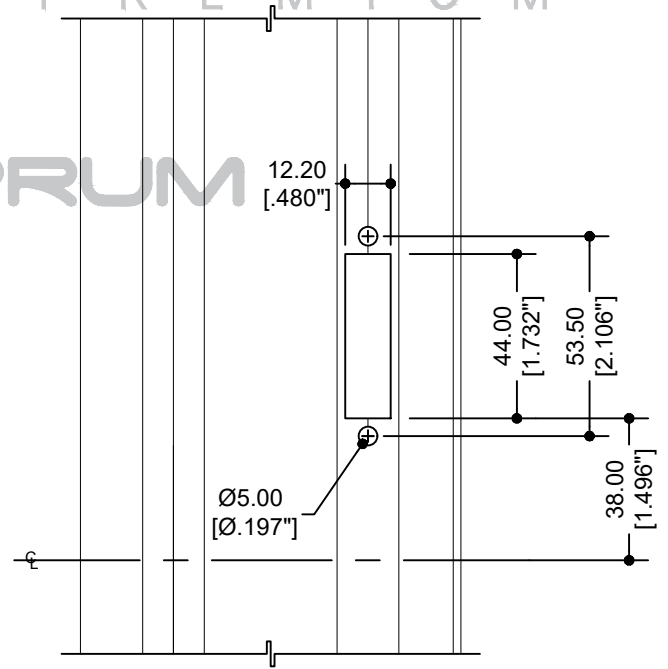
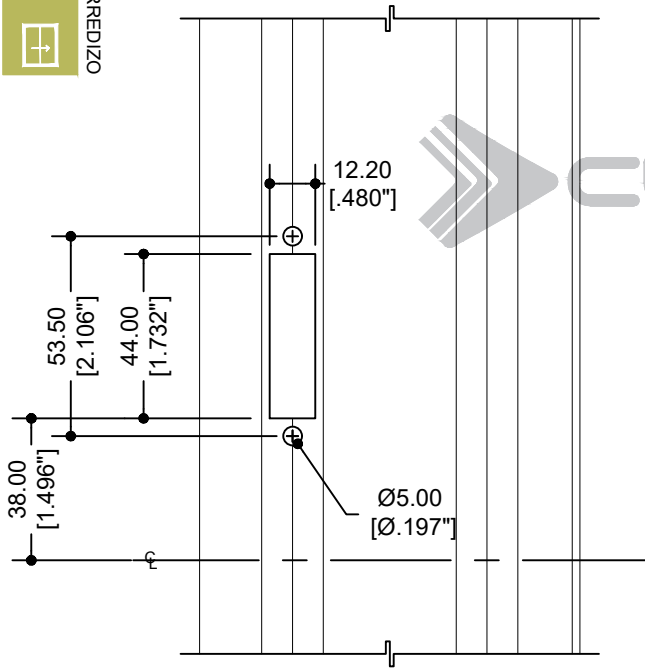

OPERACIÓN F

62054 RIEL TRIPLE

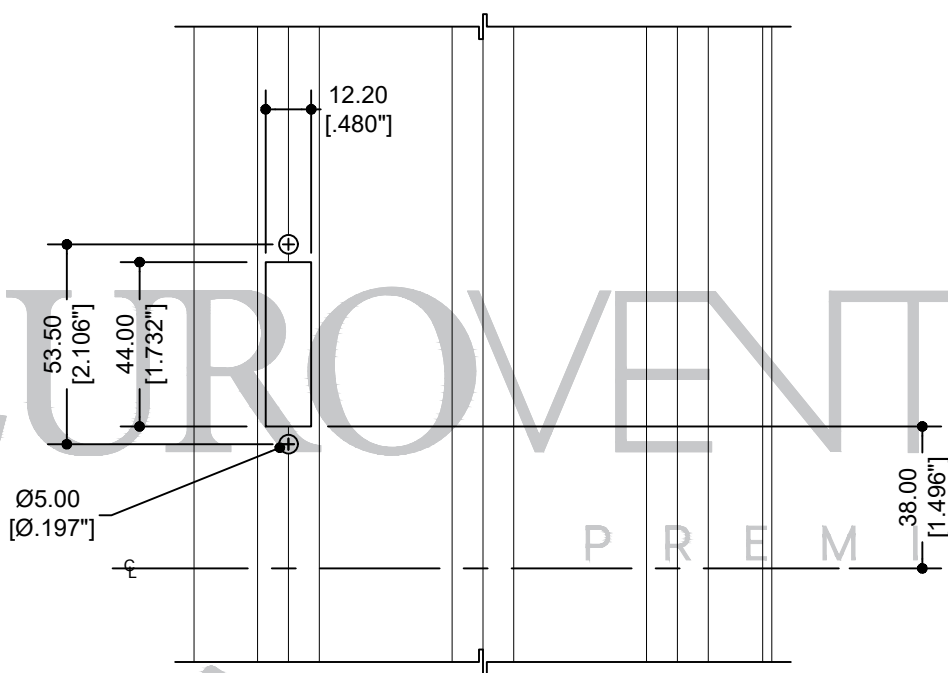
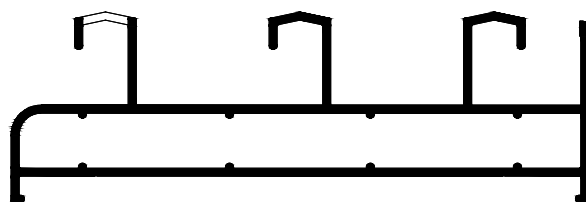

PREMIUM

SERIE

S150

CORREDIZO



RIEL TRIPLE, EL SAQUE DE LA PISTA CENTRAL ES UNA OPERACIÓN MANUAL
EL SAQUE PARA LA CONTRA DEL CIERRE SE REALIZA SEGÚN LA SOLUCIÓN DE EL CANCEL

OPERACIÓN MANUAL

64206 ADAPTADOR OXO

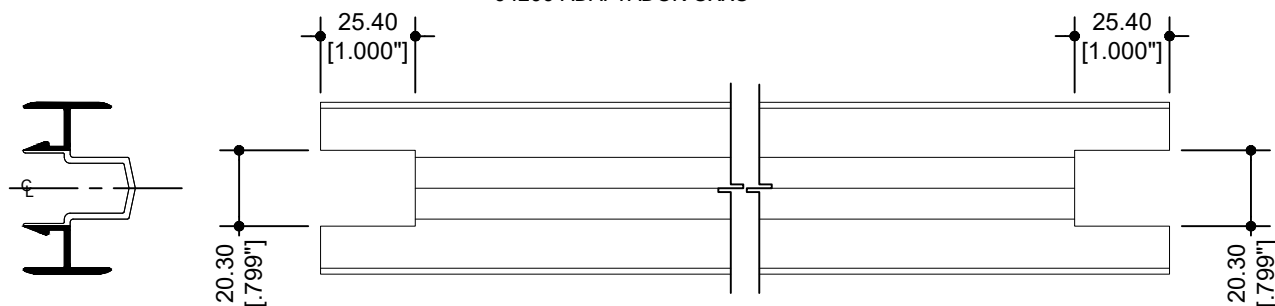

PREMIUM
SERIE

S150



CORREDIZO



TABLA DE DESCUENTOS DOS HOJAS CORREDIZAS			
CLAVE	DESCRIPCIÓN	No. DE PIEZAS	CORTE Y DESCUENTO
62052	RIEL / CABEZAL	2	L
62052	JAMBA	2	H
62055	ZOCLO / CABEZAL	4	L/2+3
62055	CERCO / TRASLAPE	4	H-78
62058	TAPA TRASLAPE	2	H-78
VIDRIO	L	2	L/2-131
	H		H-212
L= ANCHO H= ALTO		DESCUENTOS EN MM.	

CORREDIZA SERIE 150
A UNA ALTURA DE 15 METROS
DEFLEXIÓN MAX. L/175

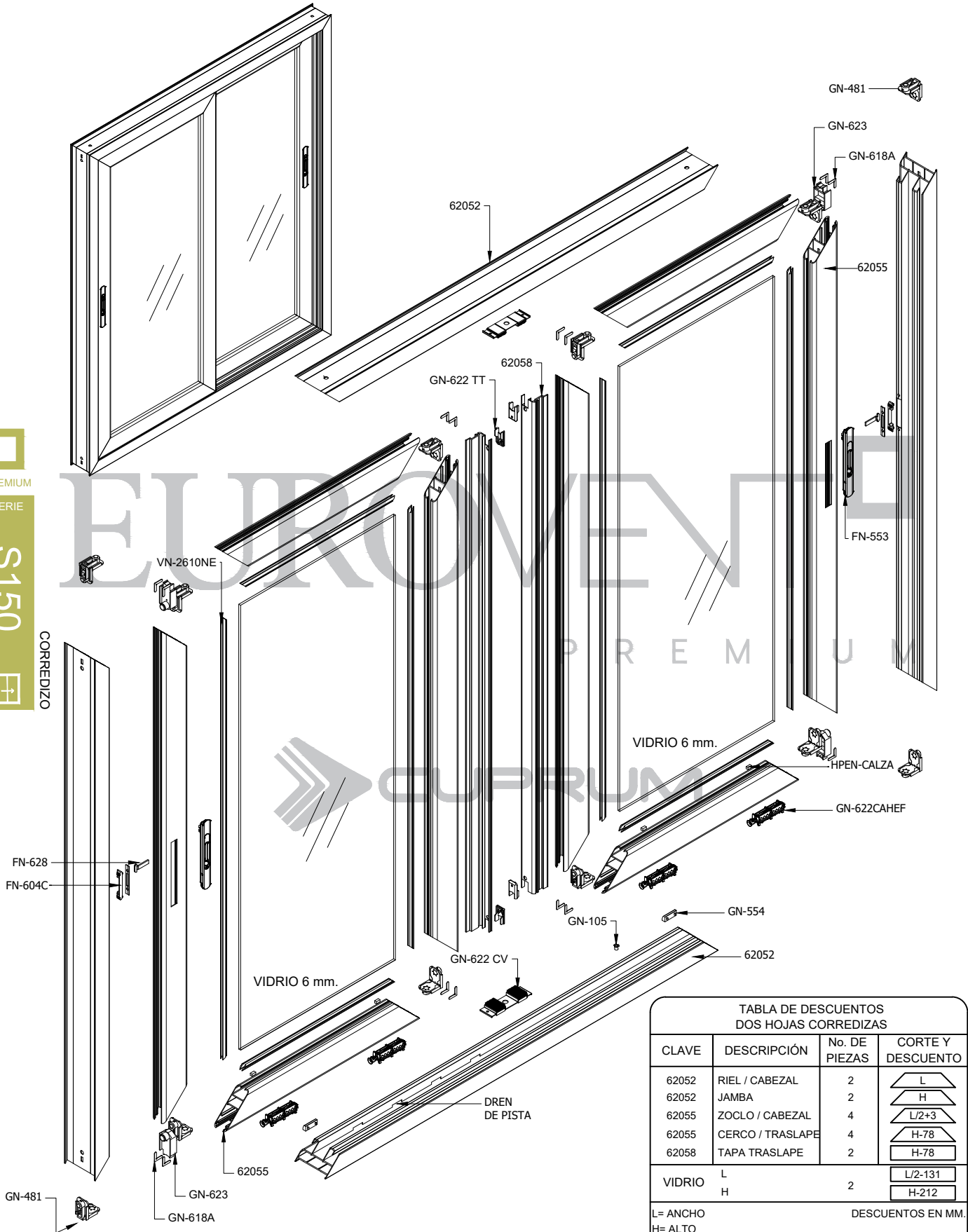
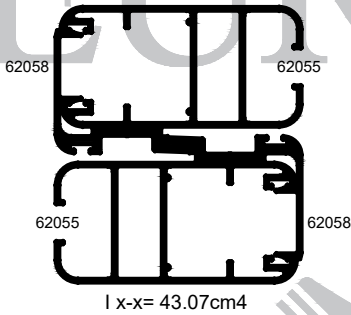
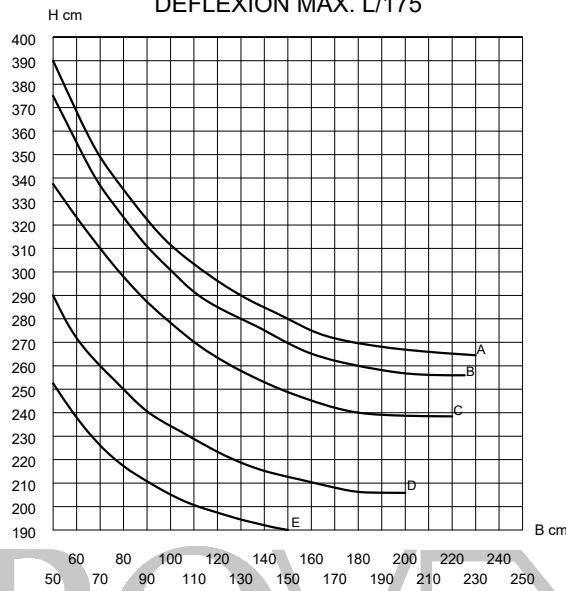

LOS LÍMITES DE FABRICACIÓN PARA LOS PERFILES, SERÁN LOS QUE SE ENCUENTREN DEBAJO DE LAS CURVAS GRAFICADAS.

ALEACIÓN: 6063
TEMPLE: 5

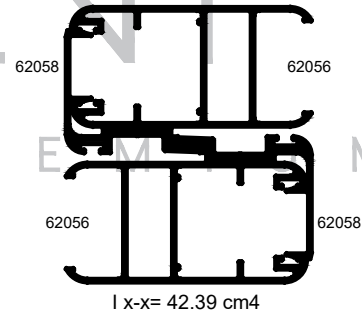

Valores de presión por velocidad de viento

Curvas	Presión del diseño	Velocidad de viento	Zona
A	45 Kg/m ²	80 Km/h	Centro de grandes ciudades
B	50 Kg/m ²	90 Km/h	Barrios Residenciales
C	65 Kg/m ²	120 Km/h	Campo Abierto
D	145 Kg/m ²	160 Km/h	Zona Costera
E	195 Kg/m ²	180 Km/h	Zona de Huracanes

LOS LÍMITES DE UN CANCEL VAN EN FUNCIÓN DE LA COMBINACIÓN DE RESISTENCIA DEL PERFIL DE ALUMINIO, EL VIDRIO Y LOS ACCESORIOS QUE LO INTEGRAN.

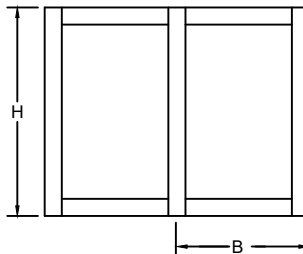

VERIFICAR QUE LA DEFLEXIÓN DEL PERFIL SEA COMPATIBLE CON EL VIDRIO UTILIZADO.

CORREDIZA SERIE 150
A UNA ALTURA DE 15 METROS

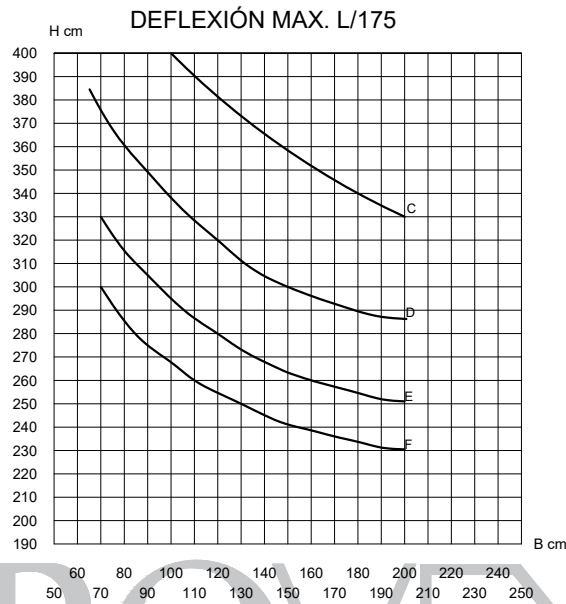

PREMIUM
SERIE
S150
CORREDIZO

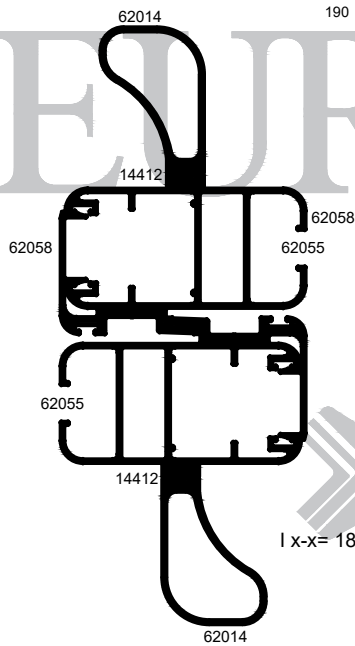

LOS LÍMITES DE FABRICACIÓN
PARA LOS PERFILES, SERÁN
LOS QUE SE ENCUENTREN DEBAJO
DE LAS CURVAS GRAFICADAS.

ALEACIÓN: 6063
TEMPLE: 5

CUPRUM

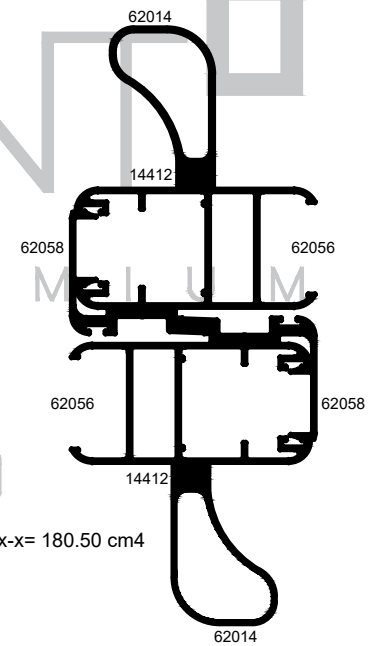

Valores de presión por velocidad de viento

Curvas	Presión del diseño	Velocidad de viento	Zona
C	65 Kg/m ²	120 Km/h	Campo Abierto
D	145 Kg/m ²	160 Km/h	Zona Costera
E	195 Kg/m ²	180 Km/h	Zona de Huracanes
F	245 Kg/m ²	220 Km/h	Zona de Huracanes

LOS LÍMITES DE UN CANCEL VAN EN FUNCIÓN DE LA
COMBINACIÓN DE RESISTENCIA DEL PERFIL DE ALUMINIO,
EL VIDRIO Y LOS ACCESORIOS QUE LO INTEGRAN.

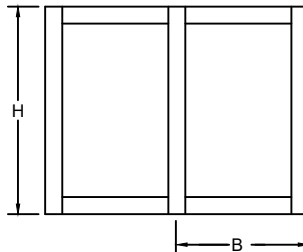

VERIFICAR QUE LA DEFLEXIÓN DEL PERFIL SEA
COMPATIBLE CON EL VIDRIO UTILIZADO.



PARÁMETROS MÍNIMOS Y MÁXIMOS DE FABRICACIÓN.

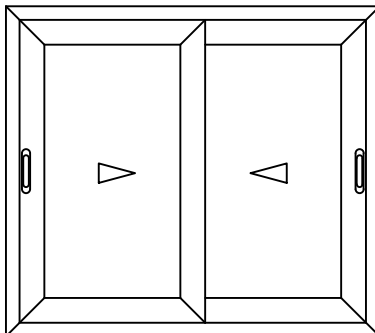

PCS-150
MÍNIMO 0.80 x 1.90 HOJA
MÁXIMO 1.50 x 3.20 HOJA

ALUMINIO					
CLAVE	DESCRIPCIÓN	PIEZAS X ATADO	LARGO STD. MTS.	PERÍMETRO ANOD. CM.	PERÍMETRO PUL. CM.
14412	CONECTOR	29	6.10	0.0	0.0
62014	REFUERZO	6	6.10	17.49	14.13
62052	RIEL DOBLE	2	6.10	49.11	37.20
62054	RIEL TRIPLE	1	6.10	68.25	51.07
62055	CERCO 6mm.	3	6.10	49.08	19.52
62056	CERCO 24mm.	3	6.10	46.18	17.81
62057	MOSQUITERO	3	6.10	45.39	13.57
62058	TRASLAPE	10	6.10	22.50	10.78
62060	ADAPTADOR CRISTAL	16	6.10	15.93	1.59
62091	ADAPTADOR RIEL	4	6.10	26.14	13.62
64206	ADAPTADOR OXO	8	6.10	22.56	12.02

PREMIUM
SERIE

S150

CORREDIZO